

Memories...  
and more

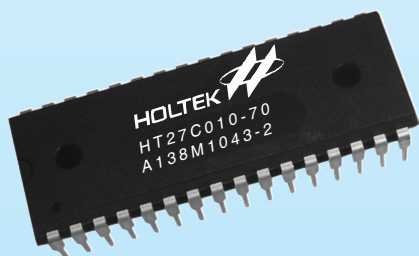

**One-Time-programmable  
EPROMs (OTP) available in  
DIP- and PLCC-Package**



**Also we offer Programming-  
and Labeling-Service.**

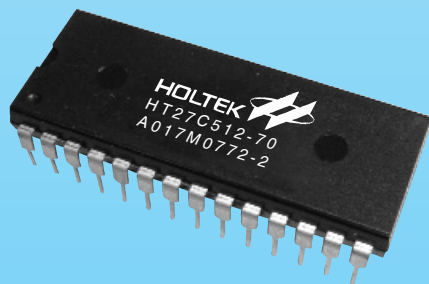
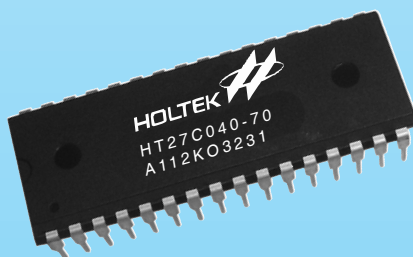
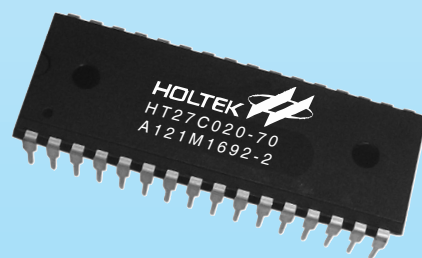

**digital electronic  
siegfried lehrer gmbh**  
Bubesheimer Str. 5  
D-89340 Leipheim (Germany)  
<http://www.digitallehrer.de>  
E-Mail: [digital@digitallehrer.de](mailto:digital@digitallehrer.de)  
Tel.: (+49)/8921-708-0  
Fax.: (+49)/8921-708-80

### Features

- Operating voltage: +5.0V
- Programming voltage
  - $V_{PP}=12.2V\pm 0.2V$
  - $V_{CC}=5.8V\pm 0.2V$
- High-reliability CMOS technology
- Latch-up immunity to 100mA from  $-1.0V$  to  $V_{CC}+1.0V$
- CMOS and TTL compatible I/O
- Low power consumption
  - Active: 30mA max.
  - Standby: 1 $\mu$ A typ.
- 64K×8-bit organization
- Fast read access time: 70ns
- Fast programming algorithm
- Programming time 75 $\mu$ s typ.
- Two line control ( $\overline{OE}$  &  $\overline{CE}$ )
- Standard product identification code
- Commercial temperature range (0°C to +70°C)
- 28-pin DIP/SOP, 32-pin PLCC package

### General Description

The HT27C512 chip family is a low-power, 512K bit, +5V electrically one-time programmable (OTP) read-only memories (EPROM). Organized into 64K words with 8 bits per word, it features a fast single address location programming, typically at 75 $\mu$ s per byte. Any byte can be accessed in less than 70ns with respect to Spec. This

eliminates the need for WAIT states in high-performance microprocessor systems. The HT27C512 has separate Output Enable ( $\overline{OE}$ ) and Chip Enable ( $\overline{CE}$ ) controls which eliminate bus contention issues.

### Block Diagram

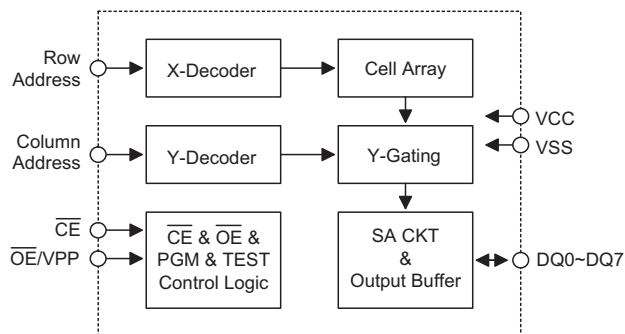

**Pin Assignment**

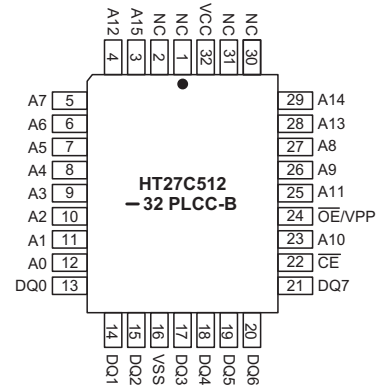
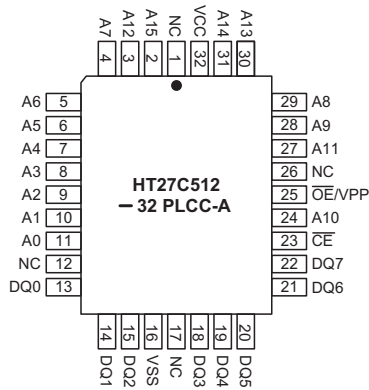
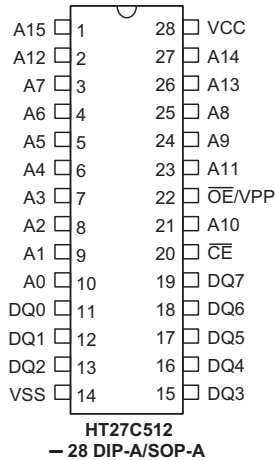

**Pin Description**

Pin Name	I/O/P	Description
A0~A15	I	Address inputs
DQ0~DQ7	I/O	Data inputs/outputs
$\overline{CE}$	I	Chip enable
$\overline{OE/VPP}$	I/P	Output enable/program voltage supply
NC	—	No connection
VCC	—	Positive power supply
VSS	—	Negative power supply, ground

**Absolute Maximum Ratings**

- Operation Temperature Commercial .....0°C to +70°C
- Storage Temperature .....-65°C to 125 °C
- Applied VCC Voltage with Respect to VSS .....-0.6V to 7.0V
- Applied Voltage on Input Pin with Respect to VSS .....-0.6V to 7.0V
- Applied Voltage on Output Pin with Respect to VSS .....-0.6V to  $V_{CC}+0.5V$
- Applied Voltage on A9 Pin with Respect to VSS .....-0.6V to 13.5V
- Applied VPP Voltage with Respect to VSS .....-0.6V to 13.5V
- Applied READ Voltage (Functionality is guaranteed between these limits) .....+4.5V to +5.5V

Note: These are stress ratings only. Stresses exceeding the range specified under "Absolute Maximum Ratings" may cause substantial damage to the device. Functional operation of this device at other conditions beyond those listed in the specification is not implied and prolonged exposure to extreme conditions may affect device reliability.

**D.C. Characteristics**

Symbol	Parameter	Test Conditions		Min.	Typ.	Max.	Unit
		V <sub>CC</sub>	Conditions				
<b>Read operation</b>							
V <sub>OH</sub>	Output High Level	5V	I <sub>OH</sub> =-0.4mA	2.4	—	—	V
V <sub>OL</sub>	Output Low Level	5V	I <sub>OL</sub> =2.1mA	—	—	0.45	V
V <sub>IH</sub>	Input High Level	5V	—	2.0	—	V <sub>CC</sub> +0.5	V
V <sub>IL</sub>	Input Low Level	5V	—	-0.3	—	0.8	V
I <sub>LI</sub>	Input Leakage Current	5V	V <sub>IN</sub> =0 to 5.5V	-5	—	5	μA
I <sub>LO</sub>	Output Leakage Current	5V	V <sub>OUT</sub> =0 to 5.5V	-10	—	10	μA
I <sub>CC</sub>	VCC Active Current	5V	$\overline{CE}=V_{IL}$ , f=5MHz, I <sub>OUT</sub> =0mA	—	—	30	mA
I <sub>SB1</sub>	Standby Current (CMOS)	5V	$\overline{CE}=V_{CC}\pm 0.3V$	—	1.0	10	μA
I <sub>SB2</sub>	Standby Current (TTL)	5V	$\overline{CE}=V_{IH}$	—	—	1.0	mA
I <sub>PP</sub>	VPP Read/Standby Current	5V	$\overline{CE}=\overline{OE}=V_{IL}$ , V <sub>PP</sub> =V <sub>CC</sub>	—	—	100	μA
<b>Programming operation</b>							
V <sub>OH</sub>	Output High Level	5.8V	I <sub>OH</sub> =-0.4mA	2.4	—	—	V
V <sub>OL</sub>	Output Low Level	5.8V	I <sub>OL</sub> =2.1mA	—	—	0.45	V
V <sub>IH</sub>	Input High Level	5.8V	—	0.7V <sub>CC</sub>	—	V <sub>CC</sub> +0.5	V
V <sub>IL</sub>	Input Low Level	5.8V	—	-0.5	—	0.8	V
I <sub>LI</sub>	Input Load Current	5.8V	V <sub>IN</sub> =V <sub>IL</sub> , V <sub>IH</sub>	—	—	5.0	μA
V <sub>H</sub>	A9 Product ID Voltage	5.8V	—	11.5	□	12.5	V
I <sub>CC</sub>	VCC Supply Current	5.8V	—	—	—	40	mA
I <sub>PP</sub>	VPP Supply Current	5.8V	$\overline{CE}=V_{IL}$	—	—	10	mA
<b>Capacitance</b>							
C <sub>IN</sub>	Input Capacitance	5V	V <sub>IN</sub> =0V	—	8	12	pF
C <sub>OUT</sub>	Output Capacitance	5V	V <sub>OUT</sub> =0V	—	8	12	pF
C <sub>VPP</sub>	VPP Capacitance	5V	V <sub>PP</sub> =0V	—	18	25	pF

**A.C. Characteristics**

Ta=25°C±5°C

Symbol	Parameter	Test Conditions		Min.	Typ.	Max.	Unit
		V <sub>CC</sub>	Conditions				
<b>Read Operation</b>							
t <sub>ACC</sub>	Address to Output Delay	5V	$\overline{CE}=\overline{OE}=V_{IL}$	—	—	70	ns
t <sub>CE</sub>	Chip Enable to Output Delay	5V	$\overline{OE}=V_{IL}$	—	—	70	ns
t <sub>OE</sub>	Output Enable to Output Delay	5V	$\overline{CE}=V_{IL}$	—	—	30	ns
t <sub>DF</sub>	$\overline{CE}$ or $\overline{OE}$ High to Output Float, Whichever Occurred First	5V	—	—	—	25	ns
t <sub>OH</sub>	Output Hold from Address, $\overline{CE}$ or $\overline{OE}$ , Whichever Occurred First	5V	—	0	—	—	ns
<b>Programming Operation</b>							
t <sub>AS</sub>	Address Setup Time	5.8V	—	2	—	—	μs
t <sub>OES</sub>	$\overline{CE}/V_{PP}$ Setup Time	5.8V	—	2	—	—	μs
t <sub>OEH</sub>	$\overline{OE}/V_{PP}$ Hold Time	5.8V	—	2	—	—	μs
t <sub>DS</sub>	Data Setup Time	5.8V	—	2	—	—	μs
t <sub>AH</sub>	Address Hold Time	5.8V	—	0	—	—	μs
t <sub>DH</sub>	Data Hold Time	5.8V	—	2	—	—	μs
t <sub>DFP</sub>	Output Enable to Output Float Delay	5.8V	—	0	—	130	ns
t <sub>PW</sub>	PGM Program Pulse Width	5.8V	—	30	75	105	μs
t <sub>VCS</sub>	VCC Setup Time	5.8V	—	2	—	—	μs
t <sub>DV</sub>	Data Valid From $\overline{CE}$	5.8V	—	—	—	150	ns
t <sub>VR</sub>	$\overline{OE}/V_{PP}$ Recovery Time	5.8V	—	2	—	—	μs

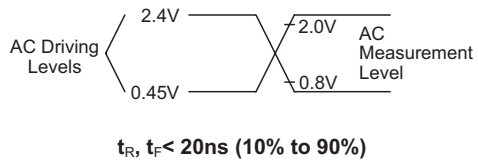
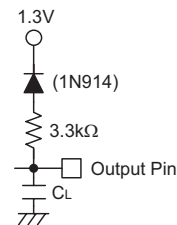
**Test Waveforms and Measurements**

**Output Test Load**

 Note: C<sub>L</sub>=100pF including jig capacitance.

## Functional Description

### Programming of the HT27C512

When the HT27C512 is delivered, the chip has all 512K bits in the "ONE" or HIGH state. "ZEROS" are loaded into the HT27C512 through the procedure of programming.

The programming mode is entered when  $12.2 \pm 0.2V$  is applied to the  $\overline{OE}/VPP$  pin and  $\overline{CE}$  is at  $V_{IL}$ . For programming, the data to be programmed is applied with 8 bits in parallel to the data pins.

The programming flowchart in Figure 3. shows the fast interactive programming algorithm. The interactive algorithm reduces programming time by using  $30\mu s$  to  $105\mu s$  programming pulses and giving each address only as many pulses as is necessary in order to reliably program the data. After each pulse is applied to a given address, the data in that address is verified. If the data is not verified, additional pulses are given until it is verified or until the maximum number of pulses is reached. This process is repeated while sequencing through each address of the HT27C512. This part of the programming algorithm is carried at  $V_{CC}=5.8V$  to assure that each EPROM bit is programmed to a sufficiently high threshold voltage. This ensures that all bits have sufficient margin. After the final address is completed, the entire EPROM memory is read at  $V_{CC}=V_{PP}=5.25 \pm 0.25V$  to verify the entire memory.

### Program Inhibit Mode

Programming of multiple HT27C512 in parallel with different data is also easily accomplished by using the Program Inhibit Mode. Except for  $\overline{CE}$ , all like inputs of the parallel HT27C512 may be common. A TTL low-level program pulse applied to an HT27C512  $\overline{CE}$  input with  $\overline{OE}/VPP=12.2 \pm 0.2V$  will program that HT27C512. A high-level  $\overline{CE}$  input inhibits the other HT27C512 from being programmed.

### Program Verify Mode

Verification should be performed on the programmed bits to determine whether they were correctly programmed. The verification should be performed with  $\overline{OE}/VPP$  and  $\overline{CE}$  at  $V_{IL}$ . Data should be verified at  $t_{DV}$  after the falling edge of  $\overline{CE}$ .

### Auto Product Identification

The Auto Product Identification mode allows the reading out of a binary code from an EPROM that will identify its manufacturer and type. This mode is intended for use by the programming equipment for the purpose of automatically matching the device to be programmed with its corresponding programming algorithm. This mode is functional in the  $25^{\circ}C \pm 5^{\circ}C$  ambient temperature range that is required when programming the HT27C512.

To activate this mode, the programming equipment must force  $12.0 \pm 0.5V$  on the address line A9 of the HT27C512. Two identifier bytes may then be sequenced from the device outputs by toggling address line A0 from  $V_{IL}$  to  $V_{IH}$ , when  $A1=V_{IH}$ . All other address lines must be held at  $V_{IH}$  during Auto Product Identification mode.

Byte 0 ( $A0=V_{IL}$ ) represents the manufacturer code, and byte 1 ( $A0=V_{IH}$ ), the device code. For HT27C512, these two identifier bytes are shown in the Operation mode truth table. All identifiers for the manufacturer and device codes will possess odd parity, with the MSB (DQ7) defined as the parity bit. When  $A1=V_{IL}$ , the HT27C512 will read out the binary code of 7F, continuation code, to signify the unavailability of manufacturer ID codes.

### Read Mode

The HT27C512 has two control functions, both of which must be logically satisfied in order to obtain data at outputs. Chip Enable ( $\overline{CE}$ ) is the power control and should be used for device selection. Output Enable ( $\overline{OE}$ ) is the output control and should be used to gate data to the output pins, independent of device selection. Assuming that addresses are stable, address access time ( $t_{AA}$ ) is equal to the delay from  $\overline{CE}$  to output ( $t_{CE}$ ). Data is available at the outputs ( $t_{OE}$ ) after the falling edge of  $\overline{OE}$ , assuming the  $\overline{CE}$  has been LOW and addresses have been stable for at least  $t_{ACC}-t_{OE}$ .

### Standby Mode

The HT27C512 has CMOS standby mode which reduces the maximum VCC current to  $10\mu A$ . It is placed in CMOS standby when  $\overline{CE}$  is at  $V_{CC} \pm 0.3V$ . The HT27C512 also has a TTL-standby mode which reduces the maximum VCC current to  $1.0mA$ . It is placed in TTL-standby when  $\overline{CE}$  is at  $V_{IH}$ . When in standby mode, the outputs are in a high-impedance state, independent of the  $\overline{OE}$  input.

### Two-line Output Control Function

To accommodate multiple memory connections, a two-line control function is provided to allow for:

- Low memory power consumption
- Assurance that output bus contention will not occur.

It is recommended that  $\overline{CE}$  be decoded and used as the primary device-selection function, while  $\overline{OE}$  be made a common connection to all devices in the array and connected to the READ line from the system control bus. This assures that all deselected memory devices are in their low-power standby mode and that the output pins are only active when data is desired from a particular memory device.

**System Considerations**

During the switch between active and standby conditions, transient current peaks are produced on the rising and falling edges of Chip Enable. The magnitude of these transient current peaks is dependent on the output capacitance loading of the device. At a minimum, a 0.1 $\mu$ F ceramic capacitor (high frequency, low inherent inductance) should be used on each device between

VCC and VPP to minimize transient effects. In addition, to overcome the voltage drop caused by the inductive effects of the printed circuit board traces on EPROM arrays, a 4.7 $\mu$ F bulk electrolytic capacitor should be used between VCC and VPP for each eight devices. The location of the capacitor should be close to where the power supply is connected to the array.

**Operation Mode Truth Table**

All the operation modes are shown in the table following.

Mode	$\overline{CE}$	OE/VPP	A0	A9	Output
Read	$V_{IL}$	$V_{IL}$	X (2)	X	Dout
Output Disable	$V_{IL}$	$V_{IH}$	X	X	High Z
Standby (TTL)	$V_{IH}$	X	X	X	High Z
Standby (CMOS)	$V_{CC} \pm 0.3V$	X	X	X	High Z
Program	$V_{IL}$	$V_{PP}$	X	X	$D_{IN}$
Program Verify	$V_{IL}$	$V_{IL}$	X	X	$D_{OUT}$
Product Inhibit	$V_{IH}$	$V_{PP}$	X	X	High Z
Manufacturer Code (3)	$V_{IL}$	$V_{IL}$	$V_{IL}$	$V_H$ (1)	1C
Device Type Code (3)	$V_{IL}$	$V_{IL}$	$V_{IH}$	$V_H$ (1)	83

- Notes: (1)  $V_H = 12.0V \pm 0.5V$   
 (2) X=Either  $V_{IH}$  or  $V_{IL}$   
 (3) For Manufacturer Code and Device Code,  $A1 = V_{IH}$ , When  $A1 = V_{IL}$ , both codes will read 7F

**Product Identification Code**

Code	Pins										Hex Data
	A0	A1	DQ7	DQ6	DQ5	DQ4	DQ3	DQ2	DQ1	DQ0	
Manufacturer	0	1	0	0	0	1	1	1	0	0	1C
Device Type	1	1	1	0	0	0	0	0	1	1	83
Continuation	0	0	0	1	1	1	1	1	1	1	7F
	1	0	0	1	1	1	1	1	1	1	7F

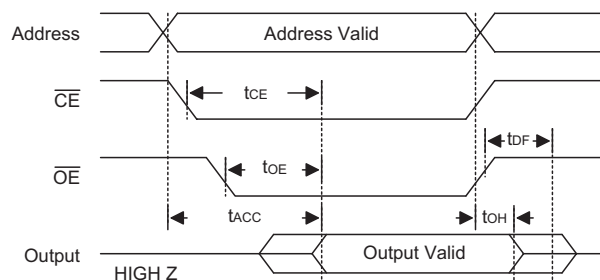

**Figure 1. A.C. Waveforms for Read Operation**

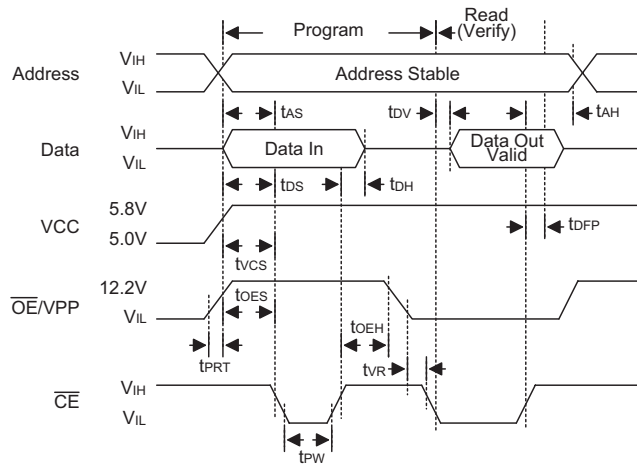
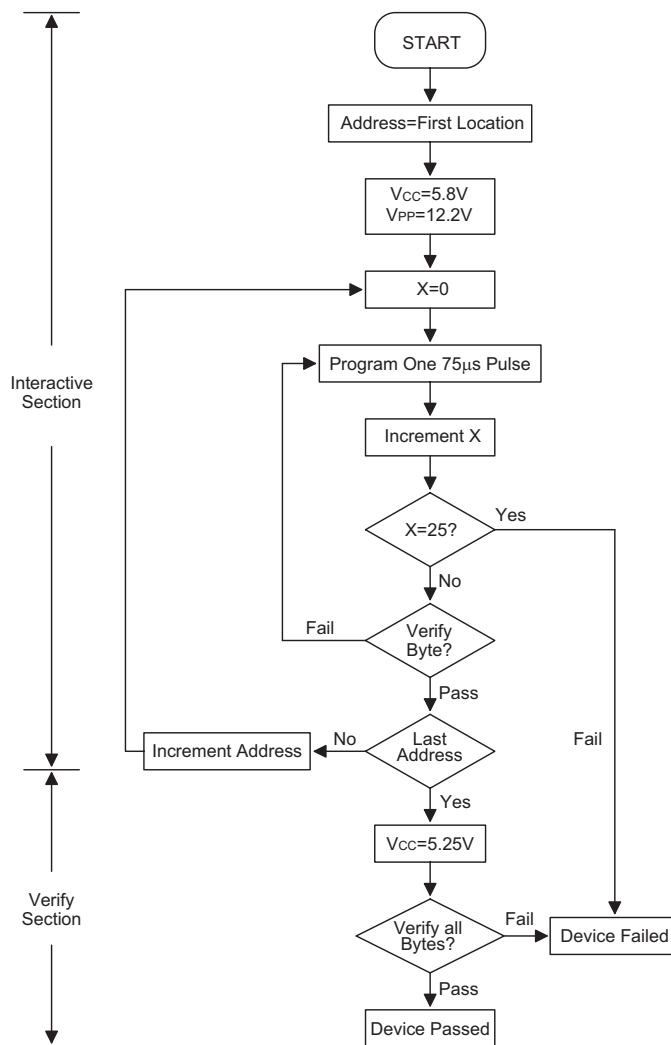

Figure 2. Programming Waveforms



Note: Either 105µs or 30µs pulse.

Figure 3. Fast Programming Flowchart

**Package Information**

28-pin DIP (600mil) Outline Dimensions

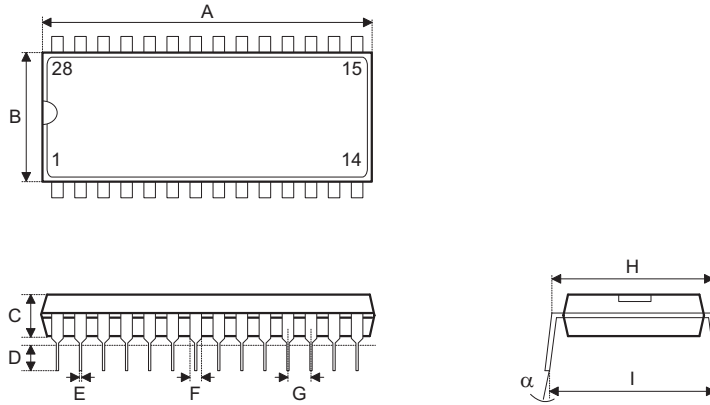

Symbol	Dimensions in mil		
	Min.	Nom.	Max.
A	1445	—	1465
B	535	—	555
C	145	—	155
D	125	—	145
E	16	—	20
F	50	—	70
G	—	100	—
H	595	—	615
I	635	—	670
$\alpha$	0°	—	15°

**28-pin SOP (300mil) Outline Dimensions**

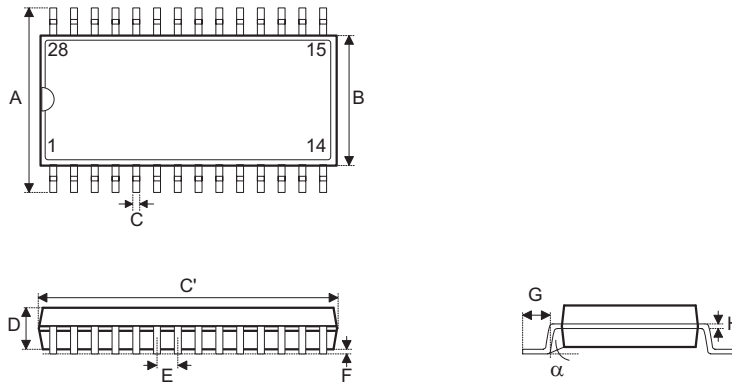

Symbol	Dimensions in mil		
	Min.	Nom.	Max.
A	394	—	419
B	290	—	300
C	14	—	20
C'	697	—	713
D	92	—	104
E	—	50	—
F	4	—	—
G	32	—	38
H	4	—	12
$\alpha$	0°	—	10°

32-pin PLCC Outline Dimensions

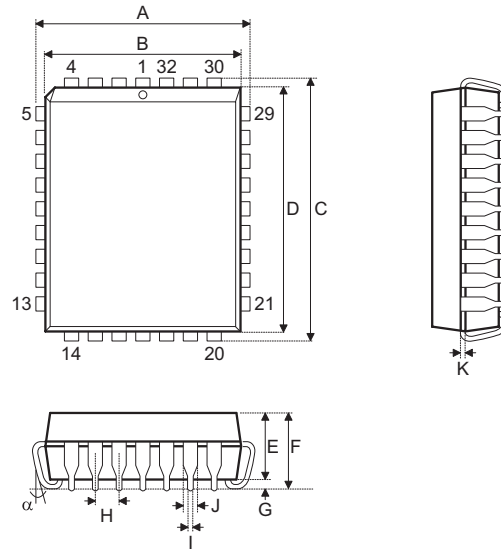

Symbol	Dimensions in mil		
	Min.	Nom.	Max.
A	485	—	495
B	445	—	455
C	585	—	595
D	545	—	555
E	105	—	115
F	—	—	140
G	15	—	—
H	—	50	—
I	16	—	22
J	24	—	32
K	8	—	12
$\alpha$	0°	—	10°

**Product Tape and Reel Specifications**

**Reel Dimensions**

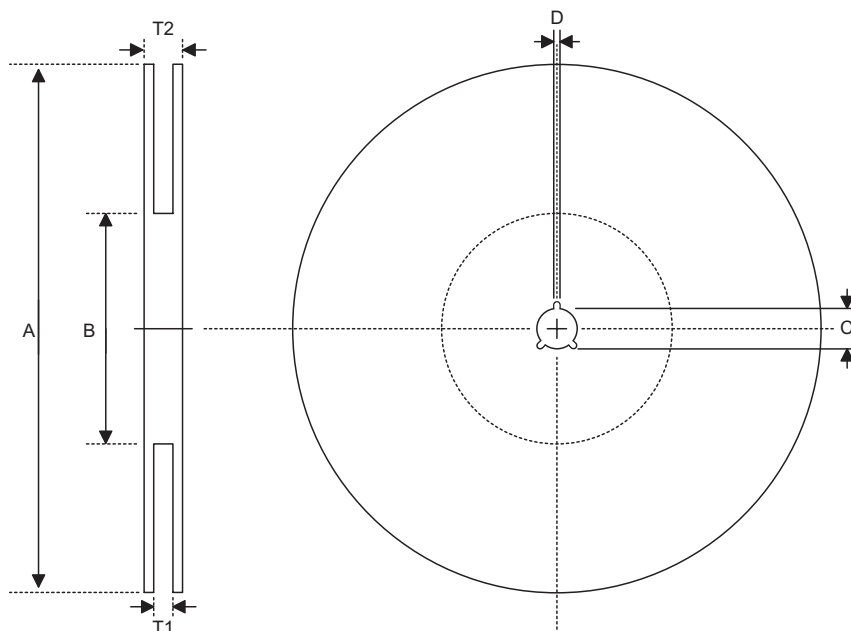

SOP 28W (300mil)

Symbol	Description	Dimensions in mm
A	Reel Outer Diameter	330±1.0
B	Reel Inner Diameter	62±1.5
C	Spindle Hole Diameter	13.0+0.5 -0.2
D	Key Slit Width	2.0±0.5
T1	Space Between Flange	24.8+0.3 -0.2
T2	Reel Thickness	30.2±0.2

PLCC 32

Symbol	Description	Dimensions in mm
A	Reel Outer Diameter	330±1.0
B	Reel Inner Diameter	62±1.5
C	Spindle Hole Diameter	13.0+0.5 -0.2
D	Key Slit Width	2.0±0.5
T1	Space Between Flange	24.8+0.3 -0.2
T2	Reel Thickness	30.2±0.2

Carrier Tape Dimensions

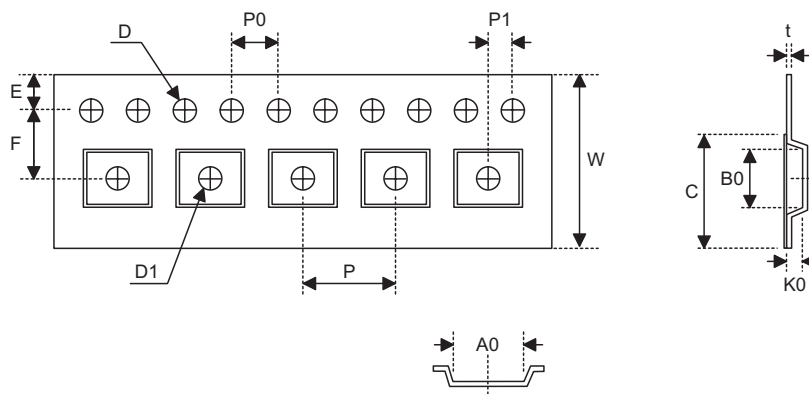

SOP 28W (300mil)

Symbol	Description	Dimensions in mm
W	Carrier Tape Width	24.0±0.3
P	Cavity Pitch	12.0±0.1
E	Perforation Position	1.75±0.1
F	Cavity to Perforation (Width Direction)	11.5±0.1
D	Perforation Diameter	1.5+0.1
D1	Cavity Hole Diameter	1.5+0.25
P0	Perforation Pitch	4.0±0.1
P1	Cavity to Perforation (Length Direction)	2.0±0.1
A0	Cavity Length	10.85±0.1
B0	Cavity Width	18.34±0.1
K0	Cavity Depth	2.97±0.1
t	Carrier Tape Thickness	0.35±0.01
C	Cover Tape Width	21.3

PLCC 32

Symbol	Description	Dimensions in mm
W	Carrier Tape Width	24.0±0.3
P	Cavity Pitch	18.0±0.1
E	Perforation Position	1.75±0.1
F	Cavity to Perforation (Width Direction)	11.5±0.1
D	Perforation Diameter	1.5+0.1
D1	Cavity Hole Diameter	1.55+1.0 -0.05
P0	Perforation Pitch	4.0±0.1
P1	Cavity to Perforation (Length Direction)	2.0±0.1
A0	Cavity Length	13.1±0.1
B0	Cavity Width	15.5±0.1
K0	Cavity Depth	3.9±0.1
t	Carrier Tape Thickness	0.30±0.05
C	Cover Tape Width	21.3