

STANDARD GRAPHIC MODULES YMC 16080-05

160 CHAR x 128 DOTS, 1/80 DUTY, 1/10 BIAS

EXTERNAL DIMENSION AND DISPLAY PATTERN

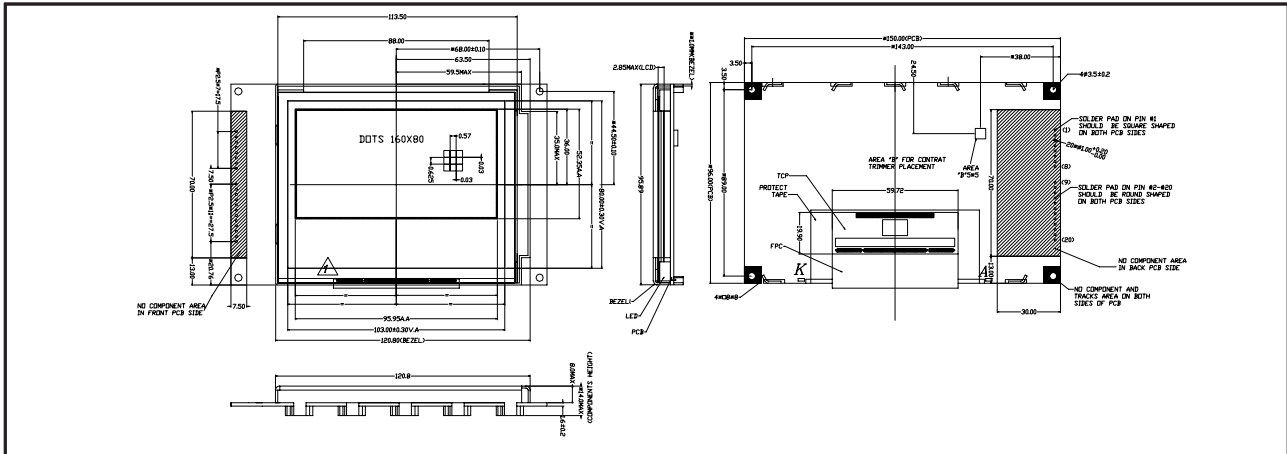

MECHANICAL DATA

ITEM	SPECIFICATION	UNIT
Module Size (W x H x T)	120.8 x 95.89 x 14.0	mm
Viewing Area (W x H)	103.0 x 80.0	mm
Number of Dots	160 x 80	dots
Character Pitch (W x H)	0.6 x 0.655	mm
Dot Size (W x H)	0.57 x 0.625	mm

ABSOLUTE MAXIMUM RATINGS

PARAMETER	SYMBOL	MIN.	MAX.	UNIT
Supply Voltage Logic	V_{CC}	-0.3	7.0	V ¹
Supply Voltage Drive	V_{LD}	-0.3	20.0	V
Input Voltage 1	V_{T1}	-0.3	$V_{CC} + 0.3$	V ^{1,2}
Input Voltage 2	V_{T2}	-0.3	$V_{LD} + 0.3$	V ^{1,3}
Operating Temperature		See page 8		
Storage Temperature				

Notes: 1. Measured Relative to GND; 2. Applies to Pins M/S, OSC, OSC₁, OSC₂, DB₇ to DB₆, /RD, /WR, /CS, RS, /RES, CL₁, M, FLM; 3. Applies to Pins V₁₀, V₂₀, V₃₀, V₄₀ and V₅₀; 4. If the LSI is used beyond its absolute max.rating, it may be permanently damaged. It should always be used within the limits of its electrical characteristics to prevent malfunction or unreliability.

PIN CONFIGURATION

PIN	SYMBOL	SIGNAL DESCRIPTION
1	V_{LED+}	LED Power
2	V_{LED-}	LED Power
3	NC	No Connection
4	RESET	Reset the LSI Internally When Drive Low
5	/RD	Inputs Read Strobe
6	/WR	Inputs Write Strobe
7	/CS	Select the LSI, Specifically Internal Registers (Index and Data Registers) when Drive Low
8	A_0	Select One of the Internal Registers
9-16	$D_0 - D_7$	Data Bus Line
17	V_{DD}	Power Supply Voltage
18	V_{DC+}	Power Supply for DC-DC
19	GND	Ground
20	NC	No Connection

ELECTRICAL CHARACTERISTICS, $T_a = 25^\circ\text{C}$

ITEM	SYMBOL	CONDITION	SPEC. VALUE			UNIT
			MIN.	TYP.	MAX.	
Supply Voltage (Logic)	$V_{DD} - V_{SS}$			3.0±10%		V
LCD Operating Voltage	$V_0 - V_{SS}$	$T_a = +25^\circ\text{C}$	15.2	15.4	15.6	V
Response Time	T_{ON} T_{OFF}			72 315		ms
Contrast	CR		2.0			
Viewing Angle	12H	θ_1	CR ≥ 2.0	45		Deg.
	6H	θ_2		65		
	3H	θ_3		55		
	9H	θ_4		55		

Note (2): Value is high reliability type.

Note (3): Electro-Optical Characteristics: See page 5.

BLOCK DIAGRAM

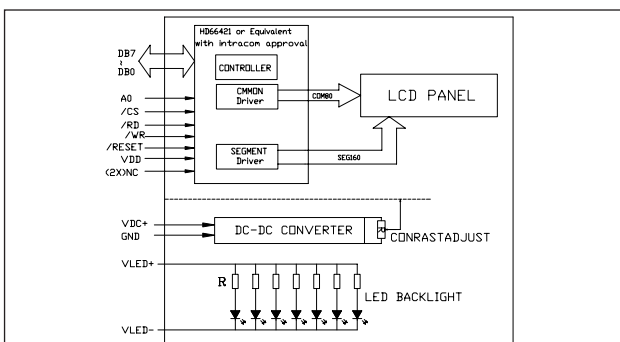

BACKLIGHTING CHARACTERISTICS, $T_a = 25^\circ\text{C}$, LED

ITEM	SYMBOL	CONDITION	SPEC. VALUE			UNIT
			MIN.	TYP.	MAX.	
Forward Voltage	V_f	$I_f = 70\text{mA}$	3.0	3.2	3.5	V
Forward Current	I_f	$V_f = 2.1\text{V}$	20	70	120	mA
Power Dissipation	P_d	$I_f = 70\text{mA}$		0.21		W
Reverse Voltage	V_r				5.0	V
Reverse Current	I_r	$V_r = 5.0\text{V}$ each chip			10	uA
Luminous Intensity	L_v	$I_f = 70\text{mA}$		TBD		cd/m ²
Luminous Uniformity	ΔL_v		65			%
Emission Wave Length	λ_p	$I_f = 20\text{mA}$ each chip	569		575	nm

Note (4): Operating Temperature Range T_{op} -20°C to +70°C; Storage Temperature Range T_{stg} -30°C to +80°C.

STANDARD GRAPHIC MODULES YMC 16080-05

160 CHAR x 128 DOTS, 1/80 DUTY, 1/10 BIAS

INTERFACE TIMING CHARACTERISTICS

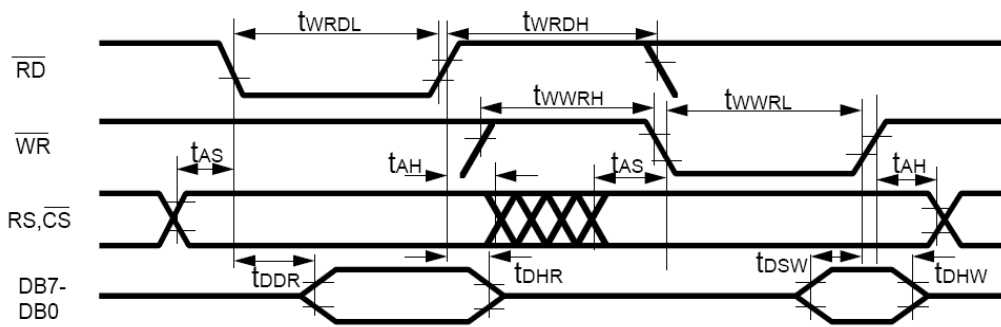
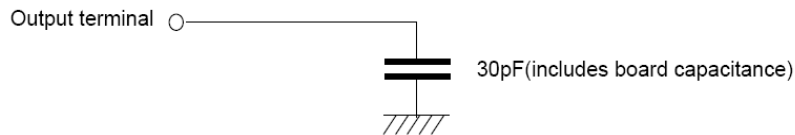

Figure 1 MPU Interface

Notes. The following load circuit is connected for specification.
VOH and VOL of the timing specification is 1/2 VCC level.



HITACHI

CLOCK CHARACTERISTICS

PARAMETER	SYMBOL	MIN.	TYP.	MAX.	UNIT	NOTES
Oscillation Frequency	f_{osc}	160	220	280	kHz	$R_f=180k\Omega$, $V_{CC}=3.0V$
External Clock Frequency	f_{CP}	50		400	kHz	
External Clock Duty Cycle	DUTY	45	50	55	%	
External Clock Fall Time	t_f			0.2	μs	
External Clock Rise Time	t_r			0.2	μs	

MPU INTERFACE

PARAMETER	SYMBOL	MIN.	TYP.	MAX.	UNIT	NOTES
RD Low Level Width	t_{WRDL}	250 190		$4t_{osc} - 450$	ns	$V_{CC}=2.2V$ to $3.0V$, ² $V_{CC}=3.0V$ to $5.5V$, ²
RD High Level Width	t_{WRDH}	450			ns	
WR Low Level Width	t_{WWRL}	250 190		$4t_{osc} - 450$	ns	$V_{CC}=2.2V$ to $3.0V$, ² $V_{CC}=3.0V$ to $5.5V$, ²
WR High Level Width	t_{WWRH}	450			ns	
Address Setup Time	t_{AS}	20			ns	
Address Hold Time	t_{AH}	20			ns	
Data Delay Time	t_{DDR}			180 150	ns	$V_{CC}=2.2V$ to $3.0V$ $V_{CC}=3.0V$ to $5.5V$
Data Output Hold Time	t_{DHR}	20			ns	
Data Setup Time	t_{DSW}	150 100			ns	$V_{CC}=2.2V$ to $3.0V$ $V_{CC}=3.0V$ to $5.5V$
Data Hold Time	t_{DHW}	10			ns	
RES Low Level Width	t_{RES}	1			ms	

Note 1: All electrical characteristics are guaranteed at +85°C for die products.

Note 2: $t_{osc}=1/f_{osc}$