

PRODUKT-INFO

HC-49/U-S QUARTZ CRYSTAL

FEATURES

1. Metal package / holder.
2. Low profile, low cost.
3. Industry standard.

Actual Size



ELECTRICAL SPECIFICATIONS	
Model	HC-49/U-S
Frequency Range	3.2 MHz ~ 70.0 MHz
Frequency Tolerance (at +25°C)	±10 ppm / ±30 ppm / ±50 ppm
Frequency Stability	±10 ppm / ±30 ppm / ±50 ppm
Load Capacitance (C _L)	10 pF ~ Series (Customer Spec.)
Drive Level	100 µW (500 µW max.)
Equivalent Series Resistance	see Table 1
Shunt Capacitance	7 pF max.
Operating Temperature Range	-10°C to +60°C, -20°C to +70°C, -40°C to +85°C option
Storage Temperature Range	-40°C to +85°C
Insulation Resistance	500 MΩ min. at 100 V _{DC}
Aging (at +25°C) first year	±5 ppm / year max.

Table 1

EQUIVALENT SERIES RESISTANCE (ESR) AND OSCILLATION MODE		
Frequency Range	ESR Ω max.	Mode / Cut
3.200 MHz ~ 4.499 MHz	150	Fundamental / AT
4.500 MHz ~ 5.999 MHz	120	Fundamental / AT
6.000 MHz ~ 6.999 MHz	100	Fundamental / AT
7.000 MHz ~ 7.999 MHz	90	Fundamental / AT
8.000 MHz ~ 8.999 MHz	80	Fundamental / AT
9.000 MHz ~ 9.999 MHz	60	Fundamental / AT
10.000 MHz ~ 12.999 MHz	50	Fundamental / AT
13.000 MHz ~ 29.999 MHz	40	Fundamental / AT
30.000 MHz ~ 70.000 MHz	80	3rd Overtone / AT
27.000 MHz ~ 40.000 MHz	40	Fundamental / BT

Dimensions (Units: mm)

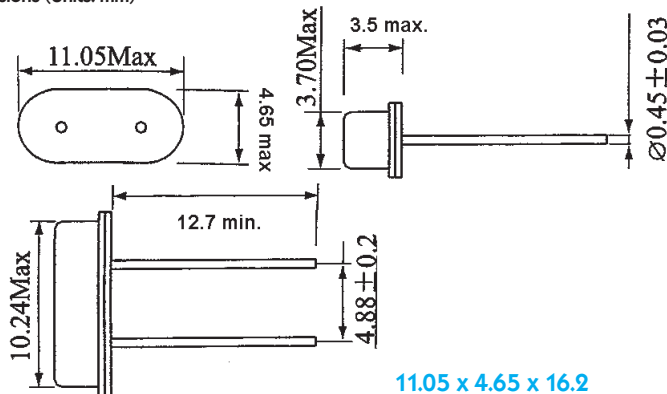

11.05 x 4.65 x 16.2

*Crystals...
and more*

Now available



**digital electronic
siegfried lehrer gmbh**
Bubesheimer Str. 5
D-89340 Leipheim (Germany)
www.digitallehrer.de
digital@digitallehrer.de

Telefon +49 (0) 82 21 / 7 08 - 0 · Telefax +49 (0) 82 21 / 7 08 - 80

All specifications subject to change without notice.