

PRODUKT-INFO

HC-49/MJ SMD CRYSTAL

FEATURES

1. HC-49/MJ is HC-49/U lead-bent gull wing type with metal jacket for easy surface mounting.
2. Wide frequency range.
3. Only available SMD-type of low frequency crystals (1.0 MHz ~ 3.2 MHz).

Actual Size



ELECTRICAL SPECIFICATIONS	
Model	HC-49/MJ
Frequency Range	1.0 MHz ~ 200.0 MHz
Load Capacitance (C _L)	10 pF ~ Series (Customer Spec.)
Drive Level	100 μW (500 μW max.)
Frequency Tolerance (at +25°C)	±10 ppm / ±30 ppm / ±50 ppm
Frequency Stability	±10 ppm / ±30 ppm / ±50 ppm
Equivalent Series Resistance	see Table 1
Shunt Capacitance	7 pF max.
Operating Temperature Range	-20°C to +70°C, -40°C to +85°C option
Storage Temperature Range	-40°C to +85°C
Insulation Resistance	500 MΩ min. at 100 V _{DC}
Aging (at +25°C) first year	±5 ppm / year max.

Table 1

EQUIVALENT SERIES RESISTANCE (ESR) AND OSCILLATION MODE		
Frequency Range	ESR Ω max.	Mode / Cut
1.000 MHz ~ 1.799 MHz	5000	Fundamental / SL
1.800 MHz ~ 2.999 MHz	400	Fundamental / AT
3.000 MHz ~ 3.999 MHz	200	Fundamental / AT
4.000 MHz ~ 4.999 MHz	150	Fundamental / AT
5.000 MHz ~ 5.999 MHz	120	Fundamental / AT
6.000 MHz ~ 6.999 MHz	100	Fundamental / AT
7.000 MHz ~ 8.999 MHz	80	Fundamental / AT
9.000 MHz ~ 12.999 MHz	60	Fundamental / AT
13.000 MHz ~ 15.999 MHz	50	Fundamental / AT
16.000 MHz ~ 19.999 MHz	40	Fundamental / AT
20.000 MHz ~ 29.999 MHz	30	Fundamental / AT
30.000 MHz ~ 69.999 MHz	100	3rd Overtone / AT
70.000 MHz ~ 99.999 MHz	40	3rd Overtone / AT
100.000 MHz ~ 200.000 MHz	70	5th Overtone / AT

Dimensions (Units: mm)

Package: HC-49/MJ

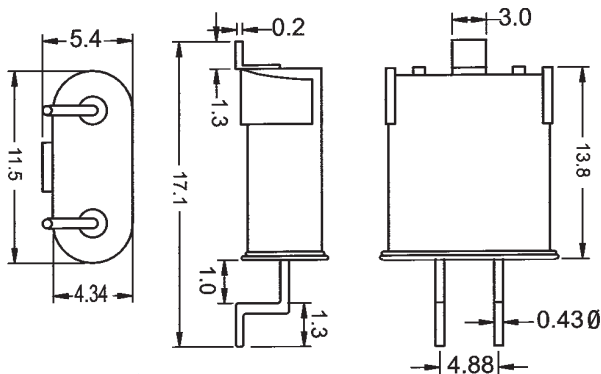

11.5 x 5.4 x 13.8/17.1

*Crystals...
and more*

Now available

RoHS
COMPLIANT
2002/95/EC



**digital electronic
siegfried lehrer gmbh**
Bubeshheimer Str. 5
D-89340 Leipheim (Germany)
www.digitallehrer.de
digital@digitallehrer.de

Telefon +49 (0) 82 21 / 7 08 - 0 · Telefax +49 (0) 82 21 / 7 08 - 80

All specifications subject to change without notice.