

# STANDARD GRAPHIC MODULES

## YMS 12864-04

128 X 64 DOTS, 1/64 DUTY, 1/9 BIAS

### EXTERNAL DIMENSION AND DISPLAY PATTERN

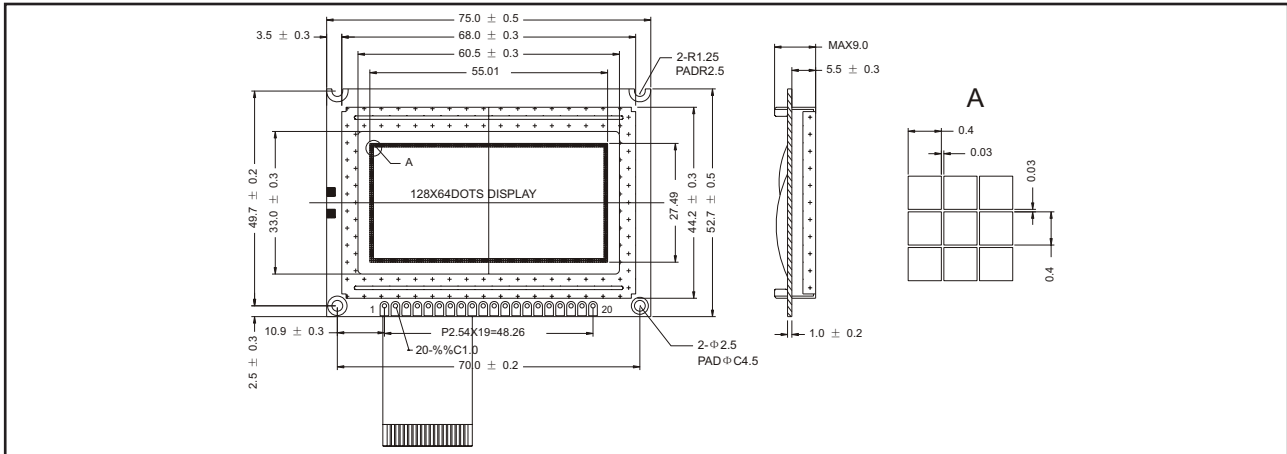

### MECHANICAL DATA

ITEM	SPECIFICATION	UNIT
Module Size (W x H x T)	75.0 x 52.7 x 9.0	mm
Viewing Area (W x H)	60.5 x 33.0	mm
Number of Dots	128 x 64	dots
Dot Pitch (W x H)	0.43 x 0.43	mm
Dot Size (W x H)	0.40 x 0.40	mm

### ABSOLUTE MAXIMUM RATINGS

PARAMETER	SYMBOL	MIN.	MAX.	UNIT
Supply Voltage Logic	$V_{DD} (V_{DD} - V_{SS})$	-0.3	7.0	V
Supply Voltage Drive	$V_{DD} - V_{EE}$	-0.3	18.0	V
Input Voltage	$V_{IN}$	-0.3	$V_{DD} + 0.3$	V
Operating Temperature	See page 8			
Storage Temperature				

### PIN CONFIGURATION

PIN	SYMBOL	LEVEL	SIGNAL DESCRIPTION
1	$V_{SS}$	0V	GND (0 V)
2	$V_{DD}$	+5V	Supply Voltage for Logic and LCD
3	$V_{EE}$		Operating Voltage for LCD (variable)
4	RS	H/L	H: DATA, L: Instruction Code
5	R/W	H/L	H: Read (Module-MPU), L: Write (MPU-Module)
6	E	H, H-L	Chip Enable Signal
7	DB <sub>0</sub>	H/L	Data Bit 0
8	DB <sub>1</sub>	H/L	Data Bit 1
9	DB <sub>2</sub>	H/L	Data Bit 2
10	DB <sub>3</sub>	H/L	Data Bit 3
11	DB <sub>4</sub>	H/L	Data Bit 4
12	DB <sub>5</sub>	H/L	Data Bit 5
13	DB <sub>6</sub>	H/L	Data Bit 6
14	DB <sub>7</sub>	H/L	Data Bit 7
15	CS <sub>1</sub>	H/L	Chip Select Signal for IC 1
16	CS <sub>2</sub>	H/L	Chip Select Signal for IC 2
17	/RES	H, H-L	Reset Signal
18	$V_{OUT}$		Power Supply Voltage for LCD
19	A		Anode of LED Unit
20	K		Cathode of LED Unit

### BLOCK DIAGRAM

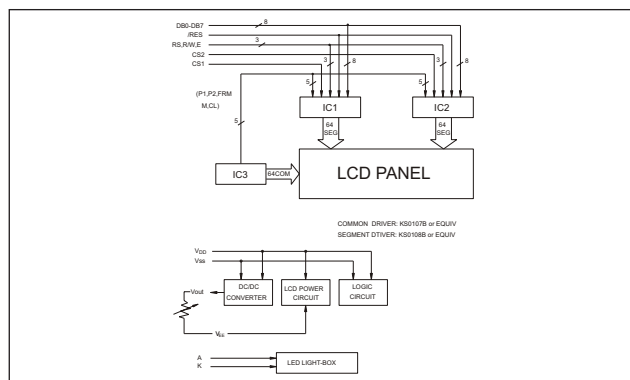

## STANDARD GRAPHIC MODULES

### YMS 12864-04

128 X 64 DOTS, 1/64 DUTY, 1/9 BIAS

#### ELECTRICAL CHARACTERISTICS, Ta = 25°C

ITEM	SYMBOL	CONDITION	SPEC. VALUE			UNIT
			MIN.	TYP.	MAX.	
Supply Voltage (Logic)	V <sub>DD</sub> - V <sub>SS</sub>		4.5	5.0	5.5	V
Supply Current (Logic)	I <sub>DD</sub>	V <sub>DD</sub> = 5V		3.0	4.5	mA
Input Voltage	HIGH	V <sub>IH</sub>	0.7 V <sub>DD</sub>		V <sub>DD</sub>	V
	LOW	V <sub>IL</sub>	0		0.3 V <sub>DD</sub>	V
Output Voltage	HIGH	V <sub>OH</sub>	I <sub>OH</sub> = 0.205mA	2.4		V
	LOW	V <sub>OL</sub>	I <sub>OL</sub> = 1.6mA		0.4	V
LCD Operating Voltage	V <sub>DD</sub> - V <sub>EE</sub>	V <sub>DD</sub> = 5V Ta = +25°C		9.7		V
Supply Current LCD Drive	I <sub>EE</sub>			3.0	4.5	mA

Note (1): Value is high reliability type.

Note (2): Electro-Optical Characteristics: See page 5.

#### BACKLIGHTING CHARACTERISTICS, Ta = 25°C, LED

ITEM	SYMBOL	CONDITION	SPEC. VALUE			UNIT
			MIN.	TYP.	MAX.	
Supply Voltage	V <sub>LED</sub>			4.1		V
Power Consumption	P <sub>LED</sub>	I <sub>F</sub> = 100mA		410		mW
Luminous	I <sub>v</sub>	I <sub>F</sub> = 100mA		60		cd/m <sup>2</sup>

#### INTERFACE TIMING CHARACTERISTICS

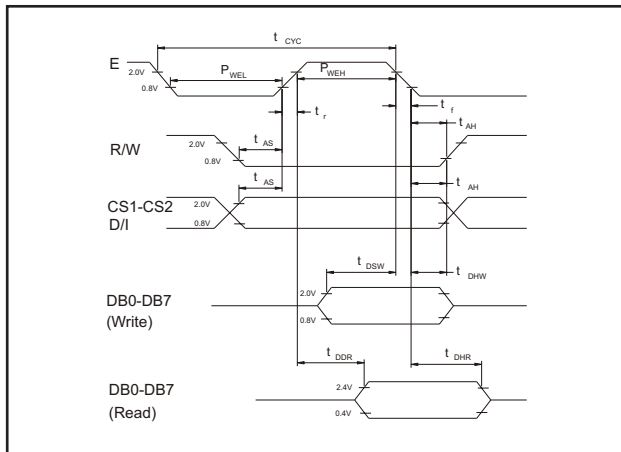

PARAMETER	SYMBOL	MIN.	MAX.	UNIT
Address Hold Time	t <sub>AH</sub>	10		ns
Address Setup Time	t <sub>AS</sub>	140		ns
E Cycle Time	t <sub>cyc</sub>	1000		ns
E High Level Width	t <sub>WEH</sub>	450		ns
E Low Level Width	t <sub>WEL</sub>	450		ns
E Rise Time	t <sub>R</sub>		25	ns
E Fall Time	t <sub>F</sub>		25	ns
Data Setup Time	t <sub>DSW</sub>	200		ns
Data Delay Time	t <sub>DDR</sub>		320	
Data Hold Time - Write	t <sub>DHW</sub>	10		ns
Data Hold Time - Read	t <sub>DHR</sub>	20		ns

Condition: V<sub>DD</sub> = +5.0 ± 10%, V<sub>SS</sub> = 0V, Ta = +25°C