

# STANDARD CHARACTER MODULES

## YMS 242-01

24 CHAR x 2 LINE, 1/16 DUTY, 1/5 BIAS

### EXTERNAL DIMENSION AND DISPLAY PATTERN

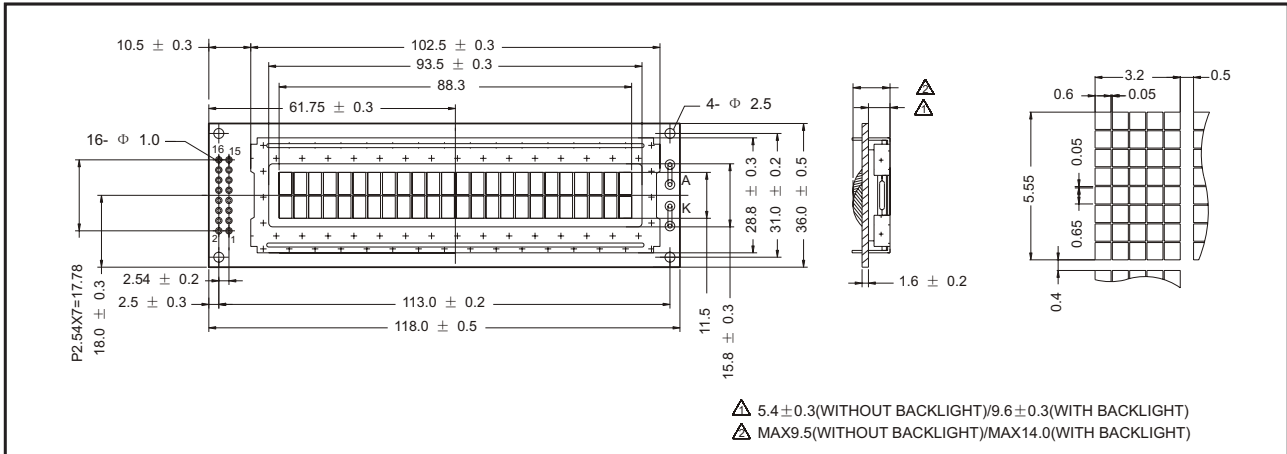

### MECHANICAL DATA

ITEM	SPECIFICATION	UNIT
Module Size (W x H x T)	118.0 x 36.0 x 9.5/14.0	mm
Viewing Area (W x H)	93.5 x 15.8	mm
Character Font (W x H)	5.0 x 7.0 with cursor	dots
Character Size (W x H)	3.2 x 5.55	mm
Character Pitch (W x H)	3.7 x 5.95	mm
Dot Size (W x H)	0.6 x 0.65	mm

### ABSOLUTE MAXIMUM RATINGS

PARAMETER	SYMBOL	MIN.	MAX.	UNIT
Supply Voltage Logic	$V_{DD} - V_{SS}$	-0.3	7.0	V
Supply Voltage Drive	$V_{DD} - V_{EE}$	3.0	11.0	V
Input Voltage	$V_{IN}$	-0.3	$V_{DD} + 0.3$	V
Operating Temperature		See page 8		
Storage Temperature		See page 8		

### PIN CONFIGURATION

PIN	SYMBOL	SIGNAL DESCRIPTION
1	$V_{SS}$	GND (0 V)
2	$V_{DD}$	Power Supply (+5.0V)
3	$V_{EE}$	Supply Voltage LCD Driver
4	RS	Register Select - LOW = Instruction, HIGH=DATA
5	R/W	Read / Write LOW = MPU to LCM, HIGH = LCM to MPU
6	E	Enable R/W = LOW: Data are talking over at falling edge R/W = HIGH: Data can be read at E = 1
7 to 14	DB <sub>0</sub> to DB <sub>7</sub>	Data Bus - Software selectable 4 or 8 bit Mode
15	A	Anode of LED Unit
16	K	Cathode of LED Unit

### ELECTRICAL CHARACTERISTICS, $T_a = 25^\circ\text{C}$

ITEM	SYMBOL	CONDITION	SPEC. VALUE			UNIT
			MIN.	TYP.	MAX.	
Supply Voltage (Logic)	$V_{DD} - V_{SS}$		4.5	5.0	5.5	V
Supply Current (Logic)	$I_{DD}$	$V_{DD} = 5V$		0.8	2.0	mA
Input Voltage	HIGH	$V_{IH}$	2.2		$V_{DD}$	V
	LOW	$V_{IL}$	-0.3		0.6	V
Output Voltage	HIGH	$V_{OH}$	$I_{OH} = 0.2mA$	2.4		V
	LOW	$V_{OL}$	$I_{OL} = 1.2mA$		0.4	V
LCD Operating Voltage	$V_{DD} - V_{EE}$	$V_{DD} = 5V$ $T_a = +25^\circ\text{C}$	4.5	4.7	5.0	V
Supply Current LCD Drive	$I_{EE}$			1.38		mA

Note (1): Value is high reliability type.

Note (2): Electro-Optical Characteristics: See page 5.

### BLOCK DIAGRAM

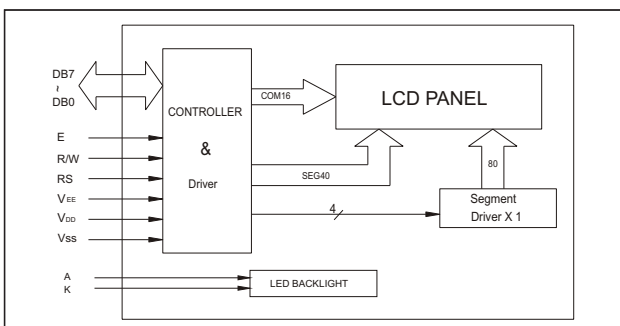

### BACKLIGHTING CHARACTERISTICS, $T_a = 25^\circ\text{C}$ , LED

ITEM	SYMBOL	CONDITION	SPEC. VALUE			UNIT
			MIN.	TYP.	MAX.	
Supply Voltage	$V_{LED}$			4.2	4.6	V
Power Consumption	$P_{LED}$	$I_F = 150mA$		630		mW
Luminous	$I_v$	$I_F = 150mA$		185		cd/m <sup>2</sup>