

TC-0101U ~ TC-0111U+ series

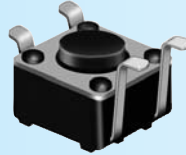

MODEL	X, Stem length, mm	Y, Knob Diameter
TC-0101U	4.2	3.5
TC-0102U	4.3	3.5
TC-0103U	5	3.4
TC-0104U	7	3.3
TC-0105U	7.3	3.3
TC-0106U	8	3.3
TC-0107U	8.5	3.1
TC-0108U	9.5	3.3
TC-0109U	12.5	3.0
TC-A109U	13.0	3.3
TC-0110U	13.5	3.2
TC-0111U	17	2.7

CIRCUIT DIAGRAM

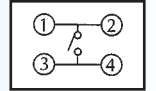

1. RATING: DC 12V 50mA

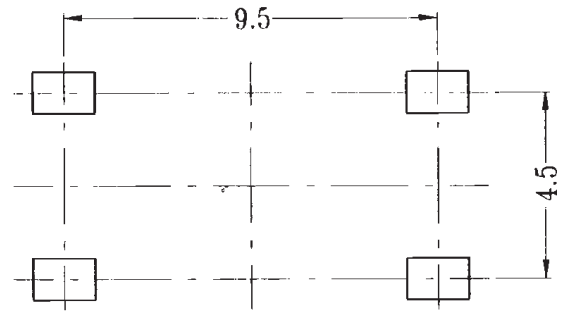
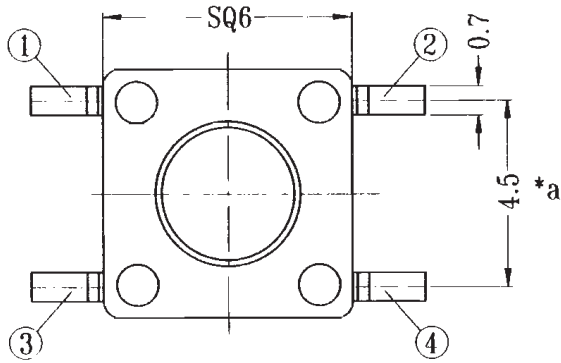

P.C.B LAYOUT  
TOP VIEW

