

LIEFERÜBERSICHT

SCHALTER & TASTER

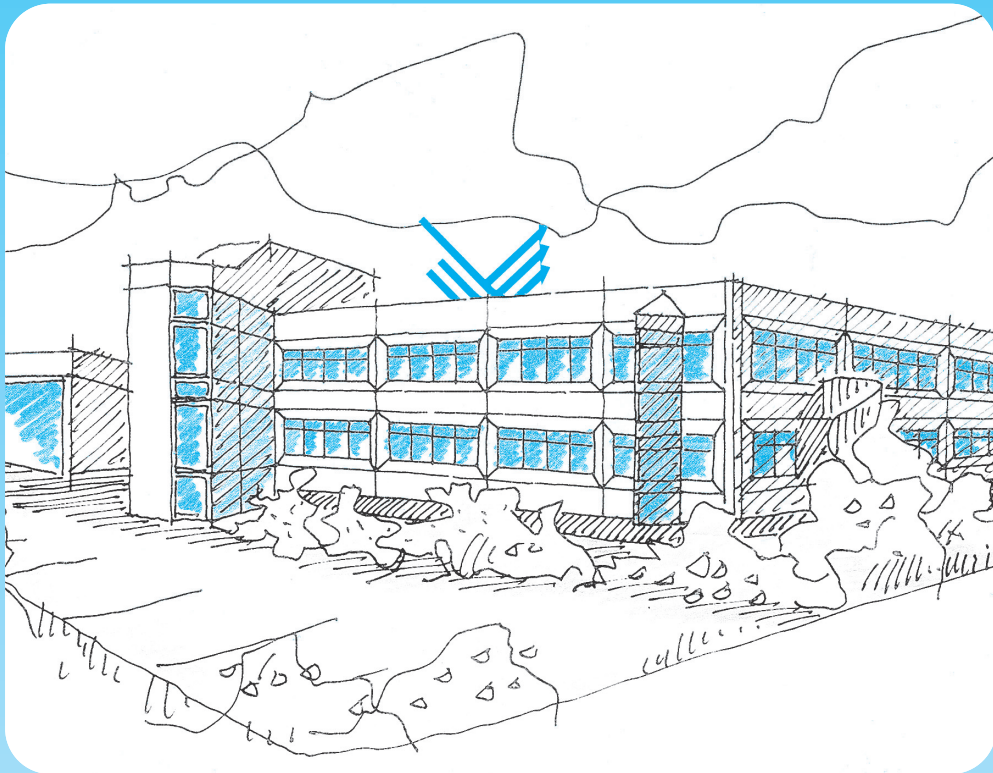

www.digitallehrer.de

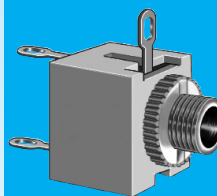
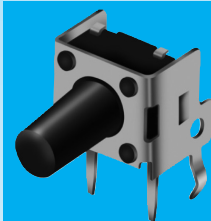
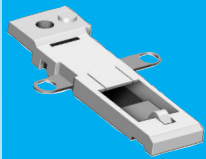

Switches

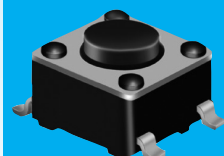
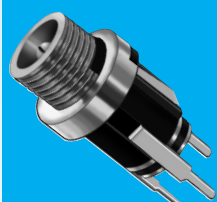
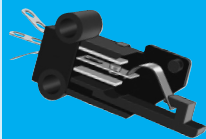





TACT SWITCHES

 4.5x4.5x2.8	 6.0x6.0	 6.0x6.0	 6.0x6.0x3.5	 6.0x3.5x3.5	 7.4x3.5x6.2	 7.4x6.6x6.6	 7.4x6.3x6.2	 7.4x6.2x7.5	 6.2x6.2x3.5
TC-0010	TC-0101 ~ TC-0111	TC-0101U ~ TC-0111U	TC-0112 ~ TC-0119+	TC-0120 ~ TC-0122	TC-0201 ~ TC-0210+	TC-0240 ~ TC-0249+	TC-024V TC-028V	TC-0250 ~ TC-0259+	TC-0302 ~ TC-0310+
 6.2x6.2x3.5	 6.2x6.2x3.5	 6.2x6.2x3.5	 6.2x6.2x3.5	 6.2x6.2x3.5	 6.2x6.2x3.5	 6.0x6.0x3.5	 LED optional 7.2x7.2x4.5	 LED optional 7.2x7.2x4.5	 7.3x6.0x4.3
TC-0311 ~ TC-0320+	TC-0324	TC-0328	TC-0401 ~ TC-0410+	TC-0411 ~ TC-0420+	TC-0424	TC-0501 ~ TC-0510+	TC-1193	TC-1194	TC-120V ~ TC-122V
 12.0x12.0x3.8	 12.0x12.0x3.8	 12.0x12.0x3.8	 12.0x12.0x3.8	 12.0x12.0x3.8	 12.0x12.0x3.8	 12.0x12.0x3.8	 7.2x7.2x5.0	 8.2x8.2x10.0	 soft touch 7.8x7.8x3.0
TC-12EA ~ TC-12XA	TC-12EB ~ TC-12XB	TC-12EC ~ TC-12XC	TC-12ED ~ TC-12XD	TC-12EF ~ TC-12XF	TC-12EM ~ TC-12XM	TC-12ET ~ TC-12XT	TC-1331	TC-1431	TC-17XA
 7.4x5.0x6.2	 6.2x6.2x3.5	 6.0x6.0x3.5	 6.0x6.0x3.5	 5.0x3.6x3.5	 6.0x6.0x3.5	 7.2x7.2x3.6	 8.0x5.5x7.4	 7.2x7.2x4.3	 6.2x6.2x6.7
TC-2301 ~ TC-2310+	TC-2324A	TC-2401 TC-2801	TC-2412	TC-3120 ~ TC-3122	TC-3301 ~ TC-3310+	TC-37XA ~ TC-37XD	TC-4203	TC-47XA ~ TC-47XD	TC-48XA
 6.0x6.0x3.5	 6.5x6.2x1.6	 6.0x3.5x3.5	 6.0x3.5x3.5	 6.0x6.0x3.5	 6.0x6.0x3.5	 6.0x6.0x3.5	 6.0x3.5x3.5	 6.0x3.5x3.5	 6.0x6.0x3.5
TC-E101 ~ TC-E111+	TD-01EA TD-01EB	TD-02EA ~ TD-02EB	TD-02XA ~ TD-02XB	TD-0341 ~ TD-0681	TD-03XA ~ TD-03XS	TD-0441	TD-05EA ~ TD-05EC	TD-05XA ~ TD-05XC	TD-06XA ~ TD-06XS
 6.5x6.2x2.0	 6.5x6.2x2.0	 6.0x3.5x3.5	 6.0x3.5x3.5	 4.5x4.5x2.8	 4.5x4.5x2.8	 6.0x3.8x2.5	 12.0x12.0x3.8	 12.0x12.0x3.8	 12.0x12.0x3.8
TD-07XA ~ TD-07XF	TD-08XA ~ TD-08XF	TD-09EA ~ TD-09EC	TD-09XA ~ TD-09XC	TD-10UA TD-10UB	TD-10XA TD-10XB	TD-11XA	TD-12EA TD-12XA	TD-12EB TD-12XB	TD-12EC TD-12XC
 12.0x12.0x3.8	 12.0x12.0x3.8	 12.0x12.0x3.8	 12.0x12.0x3.8	 12.0x12.0x3.8	 12.0x12.0x3.8	 anti-dust 5.2x5.2x1.2	 anti-dust 5.2x5.2x0.8	 7.0x3.5x2.7	 7.0x3.5x2.7
TD-12ED TD-12XD	TD-12EF TD-12XF	TD-12EK TD-12XK	TD-12EL TD-12XL	TD-12EM TD-12XM	TD-12ET TD-12XT	TD-13MA TD-13XA	TD-14XA	TD-15EA	TD-15XA
 anti-dust 7.5x4.0x1.9	 7.5x3.9x1.9	 6.1x3.7x2.5	 6.7x6.6x2.5	 6.7x6.4x2.5	 7.2x5.0x7.5	 6.0x3.5x3.5	 anti-dust, metal stem 5.0x5.0x1.3	 anti-dust, plastic stem 5.0x5.0x1.3	 4.7x3.5x1.7
TD-16EA	TD-16XA	TD-19XA	TD-20XA ~ TD-20XC	TD-20UA ~ TD-20UC	TD-2250 ~ TD-2259+	TD-22XU	TD-23MU	TD-23XU	TD-26EA TD-26XA
 4.7x3.5x1.7	 5 pins 6.2x6.5x2.0	 4 pins 6.2x6.5x2.0	 4.5x4.8x0.5	 6.1x3.7x2.0	 6.7x3.5x3.6	 5.9x6.0x5.0	 6.0x6.0x3.5	 7.1x4.0x1.7	 6.0x3.5x3.5
TD-26EU TD-26XU	TD-27XA TD-27XB	TD-28XA TD-28XB	TD-28MU	TD-29XU	TD-30EA TD-30EB	TD-31XB	TD-33XA ~ TD-33XS	TD-36EA TD-36XA	TD-42UA TD-42UB

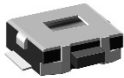
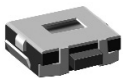
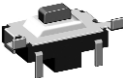
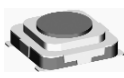

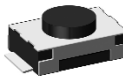
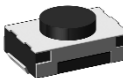



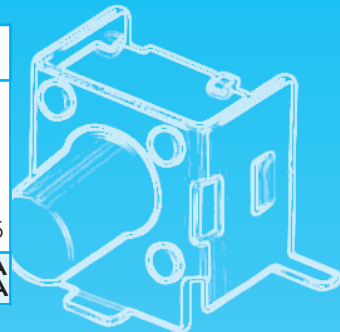











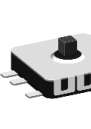

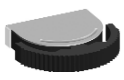
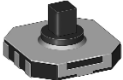
All specifications subject to change without notice. Drawings are available on request. General tolerance ± 0.2 mm. Units: mm. „+“ - more types are available.

TACT SWITCHES





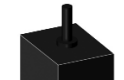
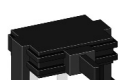

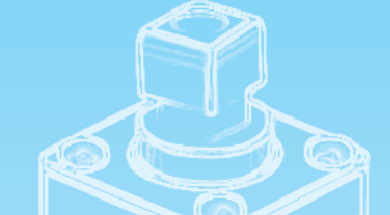











							
4.8x2.9x1.45	4.5x2.9x1.4	7.2x3.6x3.3	3.3x3.3x1.2	4.5x2.8x2.3	4.8x2.9x2.0	4.5x2.9x2.0	4.6x1.7x2.8/2.5
TD-46EA TD-46XA	TD-46EU TD-46XU	TD-65XA	TD-73XA	TD-75EA	TD-85EA TD-85XA	TD-85EU TD-85XU	TD-9005EA TD-9005XA







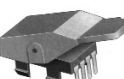











DETECTOR & MULTI FUNCTION SWITCHES

											
11.0x5.8x12.4	11.0x5.8x12.4	11.0x5.8x12.4	11.0x5.8x12.4	11.0x5.8x12.4	11.0x5.8x12.4	11.0x5.8x12.4	10.0x10.4x2.3	10.0x10.4x2.3	∅15x14.4x3.65		
CDR-3301	CDR-3302	CDR-3303	CDR-3304	CDR-3305	CDR-3307	CDR-3308	MT-003A ~MT-003C	MT-004A ~MT-004C	MT-006		
											
11.9x12.0x2.6	7.4x7.5x1.8	11.8x11.3x3.0	6.3x5.2x8.2	6.3x5.6x8.2	6.3x5.1x8.2	6.2x3.0x8.5	9.6x3.75x6.3	8.5x3.7x6.0	6.2x7.0x13.3		
MT-007	MT-008A	MT-012	TC-V030A	TC-V030B	TC-V033B	TC-0031	TC-0032	TC-0035	TC-0036		
											
5.0x4.0x6.9	9.0x5.4x5.4	6.0x4.0x9.1								TC-0040	

HOOK SWITCHES

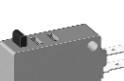
									
24.3x17.1x10.9	36.5x17.1x10.9	reverse 25.1x17.1x8.2	24.3x17.1x10.9	reverse 28.3x16.2x8.4	reverse 28.6x16.2x8.4	22.3x10.6x8.9	reverse 28.3x16.2x8.4	28.6x16.2x8.4	
HS-12L01	HS-12L02	HS-12L03	HS-12L04	HS-12L05	HS-12L06	HS-12L10	HS-12L05	HS-12L09	
									
reverse 28.6x16.2x8.4	24.3x17.1x10.9	36.5x17.1x10.9	25.1x17.1x8.2	24.3x17.1x10.9	reverse 28.3x16.2x8.4	reverse 28.6x16.2x8.4	22.3x10.6x8.9	reverse 28.3x16.2x8.4	28.6x16.2x8.4
HS-12L06	HS-22L01	HS-22L02	HS-22L03	HS-22L04	HS-22L05	HS-22L06	HS-22L10	HS-32L05	HS-32L09

MICRO SWITCHES

									
8.5x5.6x6.0	8.5x5.6x6.0	8.5x5.6x6.0	8.5x5.6x6.0	7.9x5.0x6.5	12.8x5.7x6.7	12.8x5.7x6.7	12.8x5.7x6.7	12.8x5.7x6.7	12.8x5.7x6.7
MX-001A	MX-001B	MX-001D	MX-001E	MX-1201 MX-1202	MX-1288	MX-1381	MX-1382	MX-1383	MX-1384
									
12.8x5.7x6.7	12.8x5.7x6.7	12.8x5.7x6.7	29.8x10.3x15.9	19.8x6.4x10.0	20.0x10.2x9.5	20.0x10.2x9.5	20.0x6.5x10.7		
MX-1386	MX-1387	MX-1388	MX-7001	MX-90-A01 ~MX-90-D12	MX-95	MX-95-01	MX-98		

All specifications subject to change without notice. Drawings are available on request. General tolerance ±0.2 mm. Units: mm. „+“ - more types are available.

MINI SLIDE SWITCHES

6.7x2.7x1.4	10.2x4.0x4.5	8.5x3.5x3.5	8.8x2.0x3.0	8.8x2.0x3.0	9.7x2.6x1.4	13.0x3.5x3.2	9.0x3.5x3.2	9.0x3.5x3.2	9.0x3.5x3.2
MK-12C02PA ~MK-12C02NB	MK-12D05	MK-12D13 MK-12D14	MK-12D70E ~MK-12D70RN	MK-12D70H ~MK-12D70HRN	MK-13C01PA ~MK-13C01NB	MK-13D38	MK-22D10G2 ~MK-22D10G4	MK-22D13	MK-22D14
13.0x3.5x3.2	9.0x3.5x3.2	9.0x3.5x3.2	7.2x3.5x1.5	9.0x3.5x3.5	9.0x3.5x3.5	9.0x3.5x3.5	10.0x3.5x1.5	13.0x3.5x3.2	13.0x3.5x3.2
MK-23D38	MS-12D16	MS-12D17	MS-22C01	MS-22D16	MS-22D17	MS-22D18	MS-23C01	MS-23D18	MS-23D20

VERTICAL PUSH SWITCHES







7.2x7.8x5.5	un-threaded/threaded press on 26.8xØ5.7	threaded/un-threaded press off 26.8xØ5.7	12.0x12.0x8.5	12.0x12.0x8.5	12.0x12.0x8.5	12.0x12.0x8.5	15.0x12.0x10.3	self-lock/non-lock 8.5x8.5x8.4	self-lock/non-lock 8.0x8.0x10.5
PB-11B01	PB-11C01 PB-11C02	PB-11C03 PB-11C04	PB-11D01	PB-11D03	PB-11D06	PB-11D14	PB-11E01	PB-22E06 PB-22E16	PB-22E08 PB-22E18
self-lock/non-lock 7.0x7.0x15.9	non-lock 8.0x8.0x12.5	self-lock 12.4x11.4x23.3	self-lock 12.4x11.4x20.5	self-lock 5.8x5.8x13.7	non-lock 5.8x5.8x13.7	self-lock/non-lock 8.0x8.0x13.5	non-lock/self-lock 12.0x10.0x15.1	non-lock/self-lock 21.0x10.0x8.5	13.0x8.5x8.5
PB-22E27 PB-22E37	PB-22E28	PB-22E32	PB-22E33	PB-22E60	PB-22E70	PB-22E78 PB-22E88	PBM-0102 PBM-0112	PBM-0103 PBM-0113	PB-42E01/11

LEAF SWITCHES

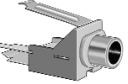
15.0x5.0x6.0	12.0x7.5x5.8	11.1x8.0x3.9	16.0x8.5x5.0	19.2x15.0x5.5	27.0x8.4x5.1	19.0x8.5x4.9	19.0x8.5x4.9	26.0x11.0x4.5	16.0x4.9x7.8
LF-001	LF-002	LF-003	LF-004	LF-006	LF-008	LF-010	LF-011	LF-013	LF-014
12.75x6.4x6.25	23.4x10.8x5.0	19.0x8.5x4.9	19.0x8.5x4.9	16.0x8.5x5.0	16.0x8.5x5.0	28.6x9.3x6.1	29.0x14.5x6.9	15.2x7.0x4.5	15.2x4.5x6.3
LF-015	LF-016	LF-020	LF-021	LF-024	LF-025	LF-028	LF-028-BR1	LF-034	LF-040
16.0x8.5x5.0	28.6x13.9x12.6	19.3x8.5x5.0	24.0x10.5x4.8	31.1x10.8x5.7					
LF-044	LF-089	LF-101	LF-103	LF-1731					

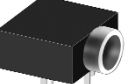

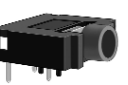



All specifications subject to change without notice. Drawings are available on request. General tolerance ± 0.2 mm. Units: mm. „+“ - more types are available.

PHONE JACKS

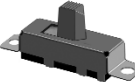
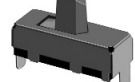
 10.8x4.3x4.7	 15.8x8.0x9.5	 19.3x9.0x10.1	 19.5x9.0x10.6	 19.5x9.0x10.6	 27.3x9.0x10.6	 27.3x9.0x10.6	 14.6x6.7x17.3	 19.3x9.0x10.1	 threaded/un-threaded 15.1x8.0x9.0
DS-613	EY-501	EY-502	EY-503NL	EY-503NR	EY-504NL	EY-504NR	EY-506C	EY-512	PY-401C PY-401N
 threaded/un-threaded 18.9x10.0x10.0	 threaded/un-threaded 19.0x15.7x10.0	 14.0x6.0x5.8	 11.0x5.0x5.8	 11.0x5.0x5.8	 13.95x7.2x5.0	 14.0x6.5x5.0	 14.0x6.5x5.0	 14.0x6.5x5.0	 14.0x6.5x5.0
PY-601C PY-601N	PY-6401C PY-6401N	ST-001	ST-002	ST-003	ST-004	ST-005	ST-006	ST-007	ST-009
 14.0x6.0x5.0	 15.0x7.0x6.0	 17.2x6.2x5.0	 17.2x6.2x5.0	 14.0x6.0x5.0	 14.0x5.5x5.0	 14.0x6.5x5.0	 12.0x9.0x4.0	 4-pin/5-pin 12.0x10.0x6.8	 5-pin 12.0x10.0x6.6
ST-010	ST-011	ST-012	ST-013	ST-014	ST-019	ST-025	ST-101 Series	ST-102-05 ST-102-06	ST-102A-06
 12.0x10.0x6.6	 12.0x10.0x6.6	 12.0x10.0x6.8	 12.0x10.0x6.5	 12.0x8.0x4.5	 13.6x6.5x4.4	 12.0x5.0x6.4	 15.0x15.6x4.3	 20.0x14.0x6.2	 11.0x5.0x5.0
ST-102B-06	ST-102C-06	ST-103-06	ST-103C-06	ST-104	ST-105	ST-106	ST-109	ST-171-01 ~ ST-171-04	ST-200
 10.0x5.0x4.0	 12.2x14.3x6.0	 12.2x19.0x6.0	 12.2x21.0x6.0	 threaded 11.3x17.6x6.0	 threaded 11.3x17.6x6.0	 18.2x8.2x12.3	 9.9x18.7x16.5	 12.2x14.1x6.0	 12.2x18.8x6.0
ST-202	ST-212-01 ~ ST-212-06	ST-212V-01 ~ ST-212V-06	ST-212W-01 ~ ST-212W-06	ST-214C	ST-214N	ST-215	ST-217N-01 ~ ST-217N-06	ST-222-01 ~ ST-222-06	ST-222V-01 ~ ST-222V-06
 12.2x20.8x6.0	 12.2x14.0x6.0	 8.2x16.2x12.3	 6.0x17.0x5.0	 7 pins 7.6x12.8x4.5	 6 pins 7.6x12.8x4.5	 6.0x12.2x4.4	 6.0x14.0x5.0	 6.0x11.8x4.4	 6.0x14.5x5.0
ST-222W-01 ~ ST-222W-06	ST-223-01 ~ ST-223-06	ST-225-01 ~ ST-225-06	ST-301	ST-303	ST-304	ST-309	ST-320	ST-331	ST-401
 5.0x12.0x3.2	 13.0x18.0x8.0	 12.0x18.0x9.0	 12.0x14.9x10.0	 12.0x20.8x10.0	 12.0x14.9x10.0	 8.5x15.8x5.0	 8.5x15.8x5.0	 8.5x15.8x5.0	 14.0x35.5x10.8
ST-409	ST-410	ST-412-01 ~ ST-412-06	ST-413-01 ~ ST-413-06	ST-413W-01 ~ ST-413W-06	ST-416-01 ~ ST-416-06	ST-603	ST-613	ST-623	MJ-062 ~ MJ-067
 10.2x35.5x10.5	 14.0x35.5x10.8	 10.2x35.5x10.5	 10.2x35.5x10.5	 10.2x35.5x10.5	 14.0x35.5x10.8	 10.2x35.5x10.5			
MJ-068	MJ-069 ~ MJ-075	MJ-078	MJ-081 ~ MJ-085	MJ-091	MJ-093 MJ-194	MJ-191 ~ MJ-292			

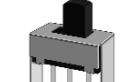
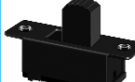
All specifications subject to change without notice. Drawings are available on request. General tolerance ± 0.2 mm. Units: mm. „+“ - more types are available.

VERTICAL SLIDE SWITCHES

									
29.6x12.2x6.0	29.6x12.2x6.0	20.2x12.2x6.0	29.6x7.2x6.0	20.0x7.2x6.0	29.6x12.2x6.0	29.2x12.2x6.0	29.2x12.2x6.0	25.5x10.3x7.6	8.5x3.5x3.5
SS-11G01	SS-11G02	SS-11G04	SS-11G05	SS-11G06	SS-11G07	SS-11G09	SS-11G11	SS-11G18	SS-12D01
									
8.6x4.4x7.3	8.5x3.5x3.5	12.7x6.6x6.4	12.8x4.4x7.5	8.6x4.4x4.7	12.7x6.6x6.4	13.2x6.6x6.4	8.6x4.4x7.3	8.6x4.4x5.7	8.6x4.4x7.5
SS-12D02	SS-12D03	SS-12D06	SS-12D07	SS-12D09	SS-12D10	SS-12D11	SS-12D12	SS-12D13	SS-12D14
									
9.4x4.5x8.5	13.3x3.5x3.5	8.6x4.4x7.5	8.6x4.4x5.7	8.6x4.4x7.5	8.6x4.4x7.5	8.6x4.4x8.0	8.6x4.4x5.7	8.6x4.4x7.5	8.6x4.4x7.5
SS-12D18	SS-12D21	SS-12D22	SS-12D23	SS-12D24	SS-12D25	SS-12D32	SS-12D33	SS-12D34	SS-12D42
									
11.5x4.0x6.0	11.5x4.0x6.0	11.5x4.4x7.0	11.5x4.0x9.0	11.5x4.0x6.5	11.5x4.0x5.0	11.5x4.0x6.5	11.5x4.0x6.0	15.5x7.5x7.2	17.0x7.5x11.5
SS-12E01	SS-12E03	SS-12E04	SS-12E05	SS-12E06	SS-12E07	SS-12E08	SS-12E09	SS-12F01	SS-12F02
									
17.0x7.5x14.0	17.0x7.5x15.0	17.0x7.5x17.0	17.0x7.5x17.0	17.0x7.5x21.0	23.2x7.5x7.2	23.2x7.5x7.2	19.7x5.6x5.0	19.6x5.6x5.0	19.6x5.6x5.0
SS-12F04	SS-12F06	SS-12F07	SS-12F08	SS-12F09	SS-12F13	SS-12F14	SS-12F15	SS-12F16	SS-12F17
									
17.0x7.5x12.0	11.2x5.6x5.0	11.2x5.6x5.0	11.2x5.6x5.0	13.0x5.8x6.9	12.2x5.6x14.0	17.0x7.5x21.0	23.2x7.5x7.2	11.2x5.6x5.0	23.2x7.5x7.2
SS-12F18	SS-12F19	SS-12F20	SS-12F21	SS-12F23	SS-12F24	SS-12F25	SS-12F26	SS-12F27	SS-12F28
									
23.2x7.5x7.2	19.6x5.6x5.0	19.6x5.6x5.0	28.2x7.5x7.2	11.2x5.6x5.0	27.0x5.6x5.0	19.6x5.6x5.0	12.2x5.6x7.0	12.2x5.6x11.0	12.2x5.6x6.5
SS-12F29	SS-12F30	SS-12F31	SS-12F32	SS-12F33	SS-12F34	SS-12F36	SS-12F37	SS-12F38	SS-12F39
									
13.5x5.6x10.5	12.2x5.6x11.0	12.2x5.6x14.0	12.2x5.6x9.0	12.2x5.6x9.0	12.2x5.6x9.0	12.2x5.6x9.0	12.2x5.6x9.7	26.5x5.5x6.0	12.2x5.6x11.5
SS-12F40	SS-12F41	SS-12F42	SS-12F43	SS-12F44	SS-12F45	SS-12F46	SS-12F47	SS-12F48	SS-12F49
									
12.2x5.6x11.5	11.4x5.6x8.8	11.4x5.6x5.0	11.4x5.6x5.0	17.0x7.5x17.0	19.6x5.6x5.0	11.4x5.6x5.0	11.4x5.6x5.0	13.5x5.6x10.5	12.2x5.6x8.7
SS-12F50	SS-12F51	SS-12F52	SS-12F53	SS-12F54	SS-12F55	SS-12F56	SS-12F57	SS-12F58	SS-12F59







All specifications subject to change without notice. Drawings are available on request. General tolerance ± 0.2 mm. Units: mm. „+“ - more types are available.

VERTICAL SLIDE SWITCHES

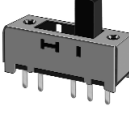
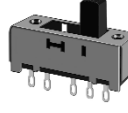
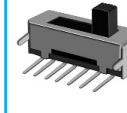
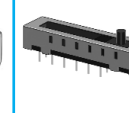
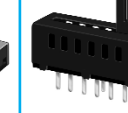
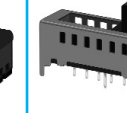
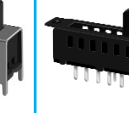
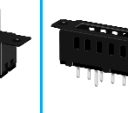
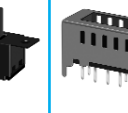
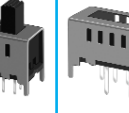
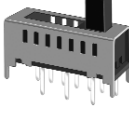
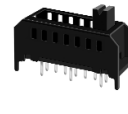
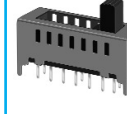
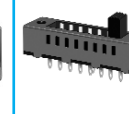
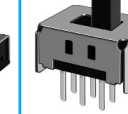
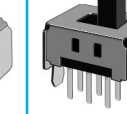
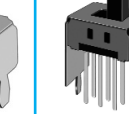
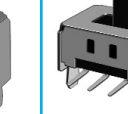
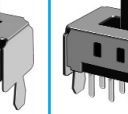
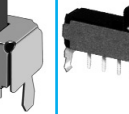
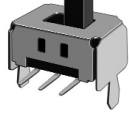
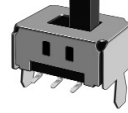
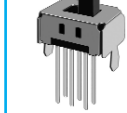
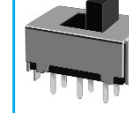
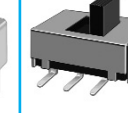
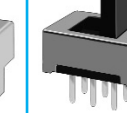
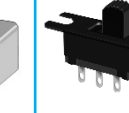
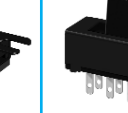
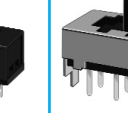
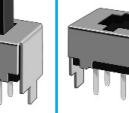
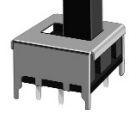
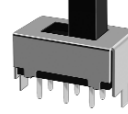
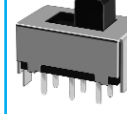
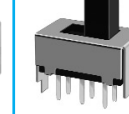
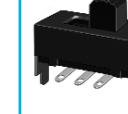
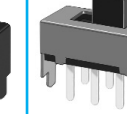
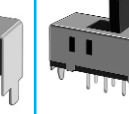
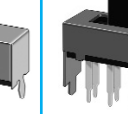
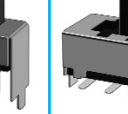
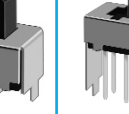
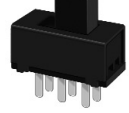
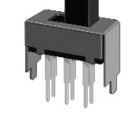
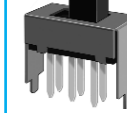
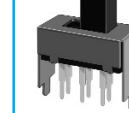
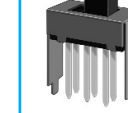
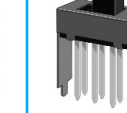
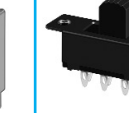
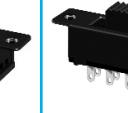
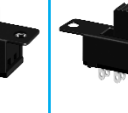
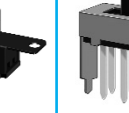
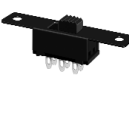
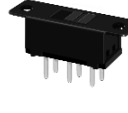
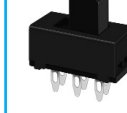
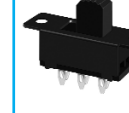
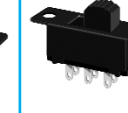
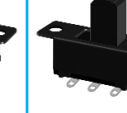
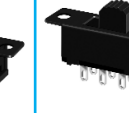
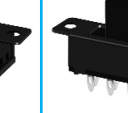
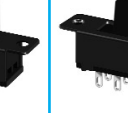
									
19.6x5.6x5.0	23.2x7.5x7.2	23.2x7.5x7.2	23.2x5.6x8.2	19.6x5.6x5.0	12.2x5.6x8.0	19.0x5.6x5.0	19.0x5.6x5.0	19.0x5.6x5.0	19.0x5.6x5.0
SS-12F61	SS-12F62	SS-12F63	SS-12F65	SS-12F66	SS-12F68	SS-12F70	SS-12F71	SS-12F72	SS-12F73
									
19.0x5.6x5.0	19.0x5.6x5.0	19.0x5.6x5.0	19.0x5.6x5.0	11.4x5.6x5.0	13.0x5.8x6.9	12.2x5.6x8.7	19.6x5.6x5.0	23.2x7.5x7.2	12.2x5.6x8.7
SS-12F75	SS-12F76	SS-12F77	SS-12F78	SS-12F79	SS-12F80	SS-12F81	SS-12F82	SS-12F85	SS-12F86
									
13.5x5.6x7.5	26.5x5.5x6.0	13.0x5.8x6.9	15.5x7.5x7.2	12.2x5.6x8.5	28.0x7.5x7.2	23.2x7.5x7.2	12.2x5.6x8.7	12.2x5.6x7.0	15.5x7.5x7.2
SS-12F87	SS-12F89	SS-12F90	SS-12F91	SS-12F92	SS-12F93	SS-12F95	SS-12F96	SS-12F97	SS-12F98
									
11.2x5.6x5.0	11.4x5.6x6.5	19.6x5.6x9.0	13.5x5.6x7.5	23.2x7.5x7.2	11.4x5.6x6.5	17.0x7.5x11.0	19.6x5.6x8.0	11.4x5.6x5.0	13.0x5.8x8.0
SS-12F100	SS-12F101	SS-12F106	SS-12F108	SS-12F110	SS-12F111	SS-12F113	SS-12F117	SS-12F120	SS-12F124
									
17.0x7.5x13.0	11.2x5.6x8.6	28.0x7.5x7.2	12.2x5.6x9.7	12.2x5.6x5.0	19.6x5.5x8.0	19.6x5.6x6.5	26.5x5.5x6.0	25.5x10.3x7.6	25.2x10.3x13.9
SS-12F128	SS-12F131	SS-12F132	SS-12F137	SS-12F147	SS-12F155	SS-12F157	SS-12F189	SS-12G08	SS-12G10
									
34.6x14.0x7.8	12.6x4.4x8.1	35.0x13.4x16.6	22.0x13.8x6.6	35.0x13.8x6.6	35.0x13.8x6.6	36.0x10.6x7.2	16.0x7.5x11.5	27.0x6.1x10.5	12.6x4.4x8.1
SS-12H08	SS-12H11	SS-12I01	SS-12I04	SS-12I05	SS-12I06	SS-12J01	SS-12L04	SS-12L07	SS-13D01
									
12.6x4.4x4.7	22.0x13.8x6.6	35.0x13.8x6.6	35.0x13.8x6.6	12.6x4.4x8.1	16.0x6.5x8.0	14.1x7.0x6.2	35.0x13.8x6.7	22.0x9.4x12.0	17.0x6.0x8.2
SS-13D02	SS-13D04	SS-13D05	SS-13D06	SS-13D11	SS-13D13	SS-13D15	SS-13D31	SS-13D43	SS-13E05
									
16.0x7.5x11.5	16.8x5.8x7.5	15.2x5.8x6.0	27.0x6.1x10.6	23.6x5.8x6.0	19.8x6.1x10.6	15.2x5.8x7.5	27.0x6.0x10.6	15.2x5.8x6.0	27.0x6.0x13.2
SS-13F03	SS-13F04	SS-13F06	SS-13F07	SS-13F08	SS-13F09	SS-13F16	SS-13F17	SS-13F20	SS-13F23
									
16.3x5.8x7.0	15.2x5.8x7.8	20.0x12.2x13.5	16.8x8.8x8.0	43.2x11.3x6.2	20.6x6.8x5.8	21.8x6.8x14.0	21.8x6.8x18.0	25.7x9.2x14.5	14.6x4.4x7.4
SS-13F24	SS-13F30	SS-13F33	SS-13F34	SS-13G02	SS-13H01	SS-13H02	SS-13H03	SS-13H12	SS-14D01

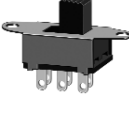
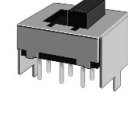
All specifications subject to change without notice. Drawings are available on request. General tolerance ± 0.2 mm. Units: mm. „+“ - more types are available.

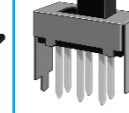
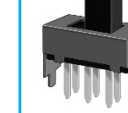
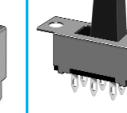
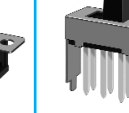
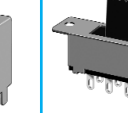
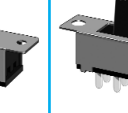
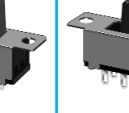
VERTICAL SLIDE SWITCHES

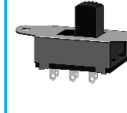
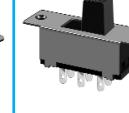
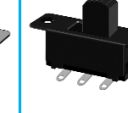
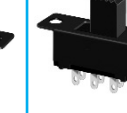
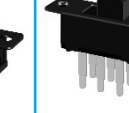
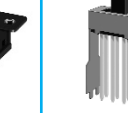
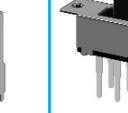
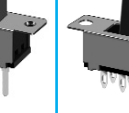
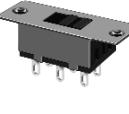
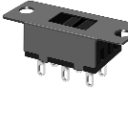
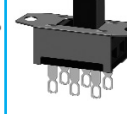
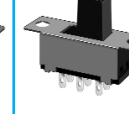
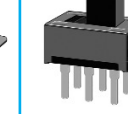
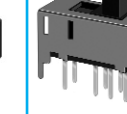
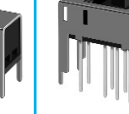
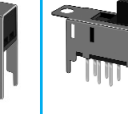
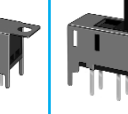
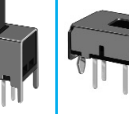
									
30.2x9.2x12.0	30.2x9.2x12.0	22.0x5.0x7.4	25.6x6.0x5.0	24.6x8.2x9.6	26.4x8.2x10.6	32.5x8.2x9.6	32.5x8.3x9.6	26.5x8.2x10.7	26.5x8.2x10.7
SS-14H03	SS-14H04	SS-15E01	SS-16F01	SS-16F02	SS-16F03	SS-16F04	SS-16F05	SS-17E01	SS-17E02
									
26.5x8.2x10.7	26.4x8.3x10.7	30.0x8.2x13.6	38.0x8.0x8.0	8.6x6.9x4.8	8.6x6.9x7.3	8.6x6.9x11.3	8.6x6.9x7.5	8.6x6.9x7.3	16.0x4.0x7.3
SS-17E03	SS-17E11	SS-17F01	SS-18F08	SS-22D02	SS-22D03	SS-22D06	SS-22D10	SS-22D13	SS-22D15
									
8.6x6.9x7.6	8.6x6.9x4.8	8.6x6.9x7.5	11.0x6.1x8.5	11.0x6.2x8.6	11.0x6.1x5.5	23.2x7.3x7.2	15.5x7.5x7.2	13.2x8.5x7.0	13.2x8.5x8.2
SS-22D20	SS-22D23	SS-22D36	SS-22E01	SS-22E10	SS-22E11	SS-22F01	SS-22F02	SS-22F03	SS-22F04
									
11.3x10.2x7.0	17.0x7.5x8.0	17.0x7.5x8.5	17.0x7.5x13.0	17.0x7.5x11.5	17.0x7.5x12.5	18.5x7.0x11.3	17.0x7.5x14.0	13.2x8.5x9.5	13.2x8.5x16.8
SS-22F05	SS-22F06	SS-22F07	SS-22F08	SS-22F09	SS-22F10	SS-22F11	SS-22F12	SS-22F13	SS-22F14
									
15.5x7.5x7.2	17.0x7.5x15.0	17.0x7.5x14.0	17.0x7.5x14.0	17.0x7.5x18.0	17.0x7.5x21.0	23.2x7.5x7.2	23.2x7.5x7.2	28.0x7.5x7.2	17.0x7.5x14.0
SS-22F15	SS-22F16	SS-22F17	SS-22F18	SS-22F20	SS-22F22	SS-22F24	SS-22F25	SS-22F26	SS-22F27
									
36.0x7.5x7.2	23.2x7.5x7.2	15.5x7.5x7.2	23.2x7.5x7.2	23.2x7.5x7.2	23.2x7.5x7.2	23.2x7.5x7.2	23.2x7.5x7.2	23.2x7.5x7.2	15.5x7.5x8.7
SS-22F28	SS-22F29	SS-22F30	SS-22F31	SS-22F32	SS-22F35	SS-22F37	SS-22F38	SS-22F39	SS-22F41
									
28.0x7.5x7.2	13.2x8.5x10.5	23.2x7.5x7.2	17.0x7.5x15.0	17.0x7.5x14.0	23.2x7.5x7.2	17.0x7.5x14.0	23.2x7.5x7.2	23.2x7.5x7.2	23.2x7.5x7.2
SS-22F43	SS-22F44	SS-22F45	SS-22F48	SS-22F50	SS-22F52	SS-22F54	SS-22F56	SS-22F57	SS-22F58
									
23.0x7.5x7.0	15.5x7.5x7.2	28.0x7.5x7.2	23.2x7.5x7.2	23.2x7.5x8.5	23.2x7.5x7.2	23.2x7.5x7.2	17.4x7.6x28.0	23.2x7.5x7.2	23.2x7.5x7.3
SS-22F59	SS-22F62	SS-22F63	SS-22F64	SS-22F65	SS-22F66	SS-22F69	SS-22F70	SS-22F79	SS-22G05
									
27.0x11.3x7.0	27.0x11.4x7.0	25.5x10.3x7.6	23.2x7.5x7.3	16.0x10.3x7.6	16.0x6.5x8.0	16.0x6.5x14.0	23.7x6.5x8.0	16.0x6.5x8.0	12.7x6.9x7.5
SS-22G06	SS-22G07	SS-22G08	SS-22G32	SS-22G88	SS-22H02	SS-22H03	SS-22H04	SS-22H05	SS-22H06

All specifications subject to change without notice. Drawings are available on request. General tolerance ± 0.2 mm. Units: mm. „+“ - more types are available.

VERTICAL SLIDE SWITCHES

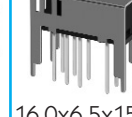
									
12.7x6.9x7.5	34.6x14.0x7.8	14.2x7.0x5.4	16.0x6.5x14.0	14.2x7.0x5.4	34.6x14.0x7.8	34.6x14.0x7.8	34.6x14.0x7.8	34.6x14.0x7.8	34.6x14.0x7.8
SS-22H07	SS-22H08	SS-22H15	SS-22H23	SS-22H25	SS-22I03	SS-22I07	SS-22I13	SS-22I24	SS-22I26
									
34.6x14.0x7.8	22.8x14.0x7.8	22.8x14.0x7.8	36.0x10.6x7.2	36.0x10.6x7.2	36.0x10.6x7.2	36.0x10.6x7.2	24.0x6.0x5.5	15.6x6.0x5.5	17.0x6.0x8.2
SS-22I27	SS-22I28	SS-22I54	SS-22J01	SS-22J03	SS-22J05	SS-22J06	SS-22J08	SS-22J09	SS-22J10
									
24.0x10.6x7.2	20.0x9.4x12.0	20.0x9.4x17.5	20.0x9.4x12.0	34.0x13.8x7.8	22.0x12.6x7.8	35.2x12.6x7.8	22.0x12.6x7.8	35.2x12.6x7.8	28.0x12.6x7.8
SS-22J11	SS-22J12	SS-22J13	SS-22J22	SS-22K22	SS-22K24	SS-22K25	SS-22K26	SS-22K28	SS-22K29
									
40.0x12.6x7.8	28.0x12.6x7.8	28.0x12.6x7.8	35.2x12.6x7.8	35.2x12.6x7.8	22.0x12.6x7.8	35.2x12.6x7.8	35.2x12.6x7.8	35.2x12.6x7.8	35.2x12.6x7.8
SS-22K30	SS-22K31	SS-22K32	SS-22K34	SS-22K35	SS-22K36	SS-22K37	SS-22K38	SS-22K39	SS-22K41
									
22.0x12.6x7.8	22.0x12.6x7.8	22.0x12.6x7.8	25.0x8.0x9.0	14.0x10.2x9.7	23.5x10.2x5.8	23.5x10.2x5.8	23.5x14.1x11.0	25.7x9.2x14.5	25.7x9.2x14.5
SS-22K44	SS-22K46	SS-22K47	SS-22L08	SS-22L13	SS-22L16	SS-22L24	SS-22N02	SS-22P01	SS-22P03
									
48.7x29.2x9.4	48.7x14.0x9.4	16.0x6.5x11.0	16.0x6.5x11.0	23.7x6.5x11.0	14.2x7.0x5.4	12.7x6.9x7.5	12.7x6.9x4.7	12.7x6.9x7.5	16.0x6.5x11.0
SS-22RQ01	SS-22RQ02	SS-23D01	SS-23D03	SS-23D04	SS-23D05	SS-23D06	SS-23D07	SS-23D08	SS-23D09
									
12.7x6.9x4.7	12.7x6.9x4.7	16.0x6.5x11.0	16.0x6.5x17.0	14.2x7.0x6.0	12.7x6.9x7.5	23.7x6.5x11.0	16.0x6.5x8.0	16.0x6.5x15.5	14.2x7.0x5.4
SS-23D10	SS-23D11	SS-23D13	SS-23D14	SS-23D15	SS-23D16	SS-23D21	SS-23D23	SS-23D24	SS-23D25
									
14.5x7.0x11.5	20.0x9.4x12.0	15.6x6.0x5.5	20.0x9.4x17.5	24.0x6.0x5.5	17.0x6.0x5.5	15.6x6.0x5.5	35.2x12.6x7.8	35.2x12.6x7.8	22.0x12.6x7.8
SS-23D28	SS-23E01	SS-23E02	SS-23E03	SS-23E04	SS-23E05	SS-23E06	SS-23E09	SS-23E10	SS-23E11
									
20.0x9.4x20.0	35.2x12.6x7.8	24.0x8.0x8.0	35.2x12.6x7.8	35.2x12.6x7.8	22.0x12.6x7.8	35.2x12.6x7.8	35.2x12.6x7.8	35.2x12.6x7.8	35.2x12.6x7.8
SS-23E12	SS-23E15	SS-23E16	SS-23E24	SS-23E25	SS-23E26	SS-23E27	SS-23E28	SS-23E29	SS-23E39

All specifications subject to change without notice. Drawings are available on request. General tolerance ± 0.2 mm. Units: mm. „+“ - more types are available.

VERTICAL SLIDE SWITCHES

									
35.2x12.6x12.0	35.2x12.6x7.8	24.2x8.0x8.1	24.2x8.0x8.1	14.0x10.2x5.8	14.0x10.2x5.8	14.0x10.2x7.0	14.0x10.2x7.0	25.0x8.0x9.0	25.0x8.0x9.0
SS-23E44	SS-23E48	SS-23F01	SS-23F02	SS-23F03	SS-23F04	SS-23F05	SS-23F06	SS-23F07	SS-23F08
									
23.0x9.6x9.8	14.0x10.2x5.8	25.0x8.0x14.0	27.0x8.0x8.1	25.0x8.0x11.5	32.6x8.0x8.2	14.0x10.2x5.8	25.0x8.0x18.0	24.2x8.0x8.1	16.0x10.2x7.0
SS-23F09	SS-23F10	SS-23F11	SS-23F12	SS-23F13	SS-23F14	SS-23F15	SS-23F16	SS-23F20	SS-23F23
									
23.5x10.2x5.8	25.0x8.0x23.0	23.5x10.2x5.8	16.0x7.5x11.3	23.5x10.2x5.8	23.5x10.2x5.8	23.5x10.2x5.8	23.5x10.2x5.8	16.8x10.2x7.2	14.0x10.2x7.0
SS-23F24	SS-23F25	SS-23F26	SS-23F31	SS-23F33	SS-23F34	SS-23F35	SS-23F36	SS-23F40	SS-23F46
									
34.6x14.0x7.8	23.5x10.2x5.8	34.6x13.8x7.8	25.7x9.2x12.0	25.7x9.2x12.0	25.7x9.2x12.0	24.2x6.5x8.5	36.5x9.2x10.4	46.0x9.2x10.4	37.7x9.2x12.0
SS-23F54	SS-23F56	SS-23F64	SS-23H02	SS-23H03	SS-23H04	SS-23H06	SS-23H11	SS-23H12	SS-23H13
									
25.7x9.2x12.0	30.2x10.2x7.6	20.4x10.2x7.6	30.2x10.2x7.6	30.2x10.6x7.8	45.5x9.2x10.4	25.7x9.2x12.0	30.2x10.6x7.8	20.4x10.6x7.8	30.2x10.2x7.6
SS-23H15	SS-23H19	SS-23H20	SS-23H25	SS-23H26	SS-23H29	SS-23H45	SS-23H49	SS-23H50	SS-23H59
									
30.2x11.4x8.0	30.2x11.4x8.0	26.5x10.2x7.0	30.5x14.0x7.8	42.0x14.0x7.8	42.0x14.0x7.8	35.0x14.0x7.8	42.0x14.0x7.8	42.0x14.0x7.8	42.0x14.0x7.8
SS-23I01	SS-23I02	SS-23J02	SS-23L02	SS-23L03	SS-23L04	SS-23L05	SS-23L07	SS-23L10	SS-23L13
									
42.0x14.0x7.8	30.5x14.1x11.0	26.0x10.2x7.0	22.0x9.4x12.0	14.6x6.9x4.7	18.0x6.2x5.2	20.0x7.5x7.5	18.0x6.2x10.0	26.0x6.2x5.2	26.0x6.2x5.2
SS-23L14	SS-23N02	SS-23R01	SS-24D01	SS-24D02	SS-24E01	SS-24E02	SS-24E03	SS-24E04	SS-24E05
									
20.0x7.5x7.5	26.0x9.4x12.0	33.5x7.0x8.5	17.0x10.2x7.0	29.6x9.2x12.0	35.0x9.2x12.0	30.2x9.2x12.0	30.2x9.2x12.0	29.6x9.2x12.0	31.2x9.2x18.0
SS-24E06	SS-24F01	SS-24F02	SS-24F03	SS-24H01	SS-24H02	SS-24H03	SS-24H04	SS-24H07	SS-24H08
									
29.6x9.2x12.0	29.6x9.2x12.0	50.0x14.0x7.8	37.2x14.1x11.0	26.0x9.4x12.0	33.5x9.2x12.0	24.2x6.5x8.5	26.5x10.2x7.0	30.2x9.4x12.0	23.0x10.0x7.0
SS-24H10	SS-24H11	SS-24N01	SS-24N02	SS-25F02	SS-25H03	SS-26D02	SS-26F01	SS-26F02	SS-26F03

All specifications subject to change without notice. Drawings are available on request. General tolerance ± 0.2 mm. Units: mm. „+“ - more types are available.

VERTICAL SLIDE SWITCHES

									
55.0x5.2x10.0	23.0x10.2x12.0	24.0x10.0x7.3	23.0x10.2x12.0	14.6x6.9x4.7	14.6x6.9x4.7	16.5x7.0x8.5	14.6x6.9x4.7	16.5x7.0x8.5	16.5x7.0x8.5
SS-29D01	SS-32F01	SS-32H01	SS-33F01	SS-42D02	SS-42D03	SS-42D04	SS-42D13	SS-42D24	SS-42D25
									
23.7x9.4x12.0	22.0x9.4x12.0	31.2x9.4x18.0	29.6x9.4x12.2	29.6x9.4x12.2	23.6x9.4x12.0	22.0x9.4x12.0	22.0x9.4x14.0	22.0x9.4x18.0	22.0x9.4x12.0
SS-42F01	SS-42F02	SS-42H01	SS-42H03	SS-42H04	SS-42H07	SS-42H08	SS-42H09	SS-42H10	SS-42H11
									
22.0x9.4x12.0	22.0x7.8x12.0	23.8x9.4x11.8	33.0x9.4x35.0	29.6x9.4x12.3	23.8x9.4x12.0	29.6x9.4x12.2	22.0x9.4x12.0	38.0x9.4x12.0	22.0x9.4x12.0
SS-42H12	SS-42H14	SS-42H18	SS-42H23	SS-42H24	SS-42H28	SS-42H33	SS-42H38	SS-42L02	SS-43D01
									
22.0x9.4x14.0	23.6x9.4x12.0	22.0x7.8x12.0	22.0x9.4x18.0	22.0x9.4x7.8	23.6x9.4x12.0	23.8x9.4x11.8	23.6x9.4x9.6	23.8x9.4x12.0	38.0x9.4x12.0
SS-43D02	SS-43D03	SS-43D04	SS-43D10	SS-43D11	SS-43D13	SS-43D21	SS-43D23	SS-43D31	SS-44D01
									
26.0x9.2x12.0	46.0x9.2x12.0	26.0x9.2x12.0	27.8x9.2x12.0	68.0x17.5x15.0	45.0x7.3x10.0	45.0x7.3x9.7	47.0x7.2x11.0	20.0x9.2x12.0	30.0x9.4x12.0
SS-44D02	SS-44D03	SS-44D04	SS-44D05	SS-45P01	SS-47D01	SS-48D01	SS-49D01	SS-62D02	SS-62F01
									
30.0x9.4x12.0	32.0x9.4x12.0	32.0x9.4x14.0	33.6x9.4x12.0	33.6x9.4x12.0	32.0x9.4x12.0	32.0x9.4x12.0	32.0x9.4x14.0	33.6x12.0x12.0	33.6x9.4x12.0
SS-62F02	SS-62H01	SS-62H03	SS-62H04	SS-62H05	SS-62H11	SS-63D01	SS-63D03	SS-63D04	SS-63D05
									
34.5x7.0x8.5	32.0x9.4x12.0	71.0x8.8x18.0	38.0x9.4x12.0	50.0x9.4x12.0	42.0x9.4x12.0	43.6x9.4x14.5	43.6x9.4x14.5	50.0x9.4x12.0	50.0x9.4x12.0
SS-63D06	SS-63D10	SS-63J01	SS-64D01	SS-82L02	SS-83D01	SS-83D02	SS-83D03	SS-83D10	SS-84D02
									
51.6x9.4x12.0	67.0x10.6x12.0	67.0x5.1x10.0	59.0x8.0x10.0	59.4x7.4x8.0					
SS-84D05	SS-85D01	SS-212D11	SS-412D01	SS-412D02					

All specifications subject to change without notice. Drawings are available on request. General tolerance ± 0.2 mm. Units: mm. „+“ - more types are available.

HORIZONTAL SLIDE SWITCHES

									
8.6x4.4x4.7	12.8x4.4x4.7	8.6x4.4x4.7	8.6x4.4x4.7	8.6x4.4x4.7	8.6x4.4x4.7	10.4x6.1x5.1	8.6x4.4x4.7	8.6x4.4x4.7	13.0x5.6x6.0
SK-12D02	SK-12D07	SK-12D09	SK-12D11	SK-12D12	SK-12D18	SK-12D19	SK-12D20	SK-12D23	SK-12E12
									
13.0x5.6x6.0	13.0x5.6x6.0	15.8x5.7x5.8	12.2x5.6x5.0	16.0x6.2x11.0	13.3x5.6x9.5	15.8x5.8x13.0	16.0x6.2x12.3	13.0x5.6x6.0	13.0x5.7x6.0
SK-12E13	SK-12E14	SK-12F02	SK-12F04	SK-12F05	SK-12F06	SK-12F09	SK-12F10	SK-12F14	SK-12F15
									
14.9x5.6x8.0	17.0x10.4x9.0	26.0x10.4x9.0	12.6x4.4x4.7	20.2x9.2x8.8	12.6x4.4x4.7	12.6x4.4x4.7	12.6x4.4x4.7	12.6x4.4x4.7	12.6x4.4x4.7
SK-12F16	SK-12G05	SK-12G06	SK-12H01	SK-12J04	SK-13D01	SK-13D02	SK-13D05	SK-13D10	SK-13D11
									
14.9x6.0x5.5	14.9x6.0x5.5	12.4x6.0x5.0	12.6x4.4x4.7	20.2x9.2x8.8	14.6x4.4x4.7	14.6x4.4x4.7	10.4x6.1x5.1	8.6x6.9x4.8	10.4x6.1x6.1
SK-13D12	SK-13D13	SK-13D18	SK-13D21	SK-13E12	SK-14D01	SK-14D02	SK-22D02	SK-22D03	SK-22D05
									
10.4x6.1x5.1	11.0x7.0x5.5	8.6x6.9x4.7	10.4x6.1x5.1	8.6x6.9x4.8	14.0x6.5x5.8	14.5x7.0x8.5	14.0x6.5x8.5	10.4x6.1x6.1	10.4x6.1x5.1
SK-22D06	SK-22D07	SK-22D09	SK-22D12	SK-22D13	SK-22D14	SK-22D15	SK-22D17	SK-22D25	SK-22D32
									
11.5x6.1x6.0	11.5x6.1x6.0	10.4x6.1x6.1	17.0x7.5x8.0	17.0x7.5x9.0	17.0x7.5x9.0	17.0x7.5x10.0	17.0x7.5x10.0	31.6x7.3x7.0	17.0x7.5x11.0
SK-22D35	SK-22D36	SK-22D45	SK-22F01	SK-22F02	SK-22F02MX	SK-22F03	SK-22F03AT	SK-22F04	SK-22F05
									
20.2x6.6x12.0	17.0x7.5x14.0	17.0x7.5x18.0	17.0x7.5x21.0	17.0x7.5x12.0	15.3x7.6x8.5	17.0x7.5x8.0	13.2x8.4x5.8	17.0x7.5x8.5	17.0x7.5x9.5
SK-22F06	SK-22F07	SK-22F08	SK-22F09	SK-22F10	SK-22F11	SK-22F12	SK-22F14	SK-22F16	SK-22F17
									
25.6x7.6x8.5	17.0x7.5x10.0	12.0x8.4x3.7	12.0x8.4x3.7	17.2x7.4x14.0	14.0x6.7x10.8	14.0x6.7x10.8	16.0x7.0x7.5	16.0x7.0x7.5	12.7x6.9x4.7
SK-22F21	SK-22F23	SK-22F24	SK-22F25	SK-22F27	SK-22H01	SK-22H02	SK-22H03	SK-22H05	SK-22H07
									
14.0x6.5x8.5	15.0x6.7x10.8	14.0x6.5x8.5	16.0x7.0x7.5	14.0x6.5x8.5	14.0x6.5x8.5	14.9x6.0x5.5	14.0x6.5x8.5	15.0x6.7x10.8	4.9x6.0x5.5
SK-22H09	SK-22H10	SK-22H11	SK-22H13	SK-22H14	SK-22H15	SK-22H18	SK-22H19	SK-22H23	SK-22H26

All specifications subject to change without notice. Drawings are available on request. General tolerance ± 0.2 mm. Units: mm. „+“ - more types are available.

HORIZONTAL SLIDE SWITCHES

									
14.9x6.0x5.5	16.0x7.0x7.5	20.0x9.4x12.0	18.1x7.5x6.6	20.0x9.4x12.0	20.2x9.2x11.0	20.0x9.4x12.0	20.0x9.4x12.0	27.2x9.2x12.0	27.2x9.2x12.0
SK-22H28	SK-22H33	SK-22J01	SK-22J02	SK-22J03	SK-22J04	SK-22J11	SK-22J13	SK-22P01	SK-22P03
									
14.0x6.7x10.8	15.0x6.7x10.8	16.0x7.0x7.5	16.0x7.0x7.5	14.9x6.0x5.5	12.7x6.9x4.7	14.9x6.0x5.5	14.0x6.5x8.5	14.9x6.0x5.5	15.0x6.7x10.8
SK-23D01	SK-23D03	SK-23D04	SK-23D05	SK-23D06	SK-23D07	SK-23D08	SK-23D09	SK-23D12	SK-23D13
									
15.8x6.9x5.5	14.5x7.0x8.5	16.0x7.0x12.5	14.0x6.5x8.5	15.0x6.7x10.8	14.0x6.7x10.8	16.0x7.0x7.5	15.0x6.7x10.8	16.0x7.0x7.5	14.5x8.5x9.0
SK-23D14	SK-23D15	SK-23D16	SK-23D19	SK-23D20	SK-23D21	SK-23D22	SK-23D23	SK-23D24	SK-23D45
									
14.5x7.0x8.5	15.0x7.0x8.0	20.0x9.4x12.0	18.1x7.5x6.6	20.0x9.4x17.5	20.0x9.4x20.0	20.0x9.4x12.0	20.2x9.2x8.8	20.0x9.4x16.0	20.0x9.4x16.0
SK-23D55	SK-23D103	SK-23E01	SK-23E02	SK-23E03	SK-23E06	SK-23E07	SK-23E12	SK-23E13	SK-23E23
									
25.0x10.5x14.0	27.2x9.2x12.0	27.2x9.2x12.0	27.2x9.2x12.0	27.2x9.2x12.0	18.0x10.5x11.5	14.6x6.9x4.7	16.5x7.0x8.5	14.6x6.9x4.7	26.0x9.4x12.0
SK-23F01	SK-23H01	SK-23H02	SK-23H04	SK-23H05	SK-24D01	SK-24D02	SK-24D03	SK-24D22	SK-24F01
									
31.0x9.2x12.0	31.0x9.2x12.0	14.6x6.8x7.2	14.6x6.8x7.2	14.6x6.8x7.2	14.6x6.8x7.2	15.0x6.2x5.2	14.6x6.9x4.7	15.0x6.2x5.2	14.0x7.2x7.5
SK-24H02	SK-24H04	SK-42C04 SK-42C14	SK-42C06 SK-42C16	SK-42C07 SK-42C17	SK-42C09 SK-42C19	SK-42D01	SK-42D03	SK-42D05	SK-42D15
									
21.0x9.4x12.0	22.6x9.4x19.5	23.6x9.4x12.0	22.0x9.4x12.0	23.6x9.4x12.0	22.0x9.4x12.0	23.6x9.4x12.0	22.0x9.4x12.0	23.0x6.0x5.0	23.0x6.0x5.0
SK-42F01	SK-42F02	SK-42H01	SK-42H03	SK-42H04	SK-42H13	SK-43D01	SK-43D03	SK-43D08	SK-43D09
									
23.7x9.4x12.0	22.0x7.8x12.0	33.5x7.0x8.5	38.0x9.4x12.0	39.5x7.0x8.5	32.0x9.4x12.0	33.5x9.4x12.0	32.0x9.4x12.0	32.0x9.4x12.0	32.0x9.4x12.0
SK-43D11	SK-43D14	SK-43F01	SK-44D01	SK-44F01	SK-62H01	SK-62H03	SK-62H11	SK-62H12	SK-63D01
									
33.5x9.4x12.0	32.0x9.4x12.0	32.0x9.4x12.0	38.0x9.4x12.0	38.0x9.4x12.0	39.6x9.4x12.0	42.0x9.4x12.0	50.0x9.4x12.0	42.0x9.4x12.0	50.0x9.4x12.0
SK-63D03	SK-63D10	SK-63D11	SK-63D15	SK-64D01	SK-64D03	SK-82D08	SK-82H01	SK-82H02	SK-82H08

All specifications subject to change without notice. Drawings are available on request. General tolerance ± 0.2 mm. Units: mm. „+“ - more types are available.

HORIZONTAL SLIDE SWITCHES

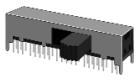
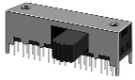
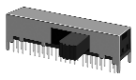
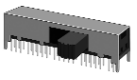
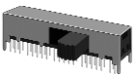
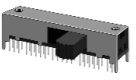
					
50.0x9.4x12.0	42.0x9.4x12.0	50.0x9.4x12.0	50.0x9.4x12.0	50.0x9.4x12.0	50.0x9.4x12.0
SK-82L01	SK-83D02	SK-83D07	SK-83D08	SK-84D01	SK-84D02

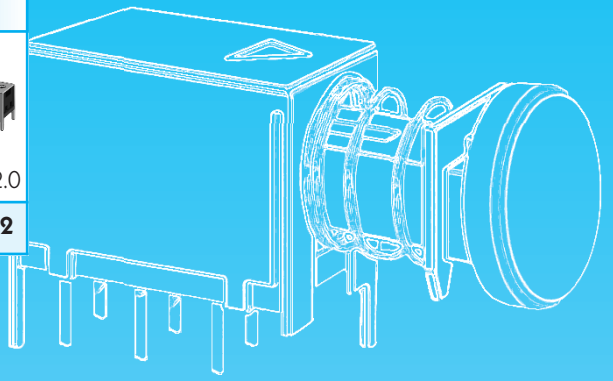

PUSH SWITCHES

									
35.0x13.5x7.0	35.0x13.5x7.0	42.7x25.8x9.5	22.0x5.0x11.1	22.0x5.0x11.1	22.0x5.0x11.1	22.0x5.0x11.1	22.0x5.0x11.1	22.0x5.0x11.1	42.7x25.8x9.5
PS-11A02	PS-11A03	PS-11E01	PS-12E01	PS-12E03	PS-12E05	PS-12E06	PS-12E10	PS-12E15	PS-12E21
									
9.0x24.0x9.2	12.4x6.0x10.0	12.4x6.0x10.0	12.4x6.0x10.0	35.0x13.4x11.0	19.6x6.8x5.5	20.0x6.5x6.2	19.2x9.2x4.6	19.2x9.2x4.6	22.0x6.6x8.3
PS-12F01	PS-12F03	PS-12F04	PS-12F14	PS-12I03	PS-22D02	PS-22D12	PS-22E02	PS-22E03	PS-22E05
									
22.0x6.6x8.3	21.2x7.7x10.0	24.9x7.7x10.0	24.9x7.7x10.0	15.5x18.0x8.5	24.9x7.7x15.5	24.9x25.6x10.0	24.9x7.7x15.5	15.7x18.0x8.5	24.9x7.7x15.3
PS-22E15	PS-22F01	PS-22F02	PS-22F03	PS-22F04	PS-22F05	PS-22F06	PS-22F07	PS-22F08	PS-22F09
									
24.9x7.7x15.3	24.9x7.7x10.0	24.9x25.6x10.0	24.9x7.7x10.0	15.7x18.0x8.5	24.9x7.7x15.5	24.9x7.7x10.0	24.9x7.7x15.5	15.7x18.0x8.5	27.1x7.7x15.3
PS-22F10	PS-22F11	PS-22F12	PS-22F13	PS-22F14	PS-22F15	PS-22F16 PS-22F19	PS-22F17	PS-22F18	PS-22F20
									
14.4x7.7x9.8	24.9x7.7x10.0	24.9x7.7x10.0	14.4x7.7x9.8	24.9x7.7x15.5	24.9x25.6x10.0	24.9x7.7x15.5	24.9x7.7x15.5	27.1x7.7x15.3	27.1x7.7x15.3
PS-22F21	PS-22F22	PS-22F23	PS-22F24	PS-22F25	PS-22F26 PS-22F32	PS-22F27	PS-22F28	PS-22F29	PS-22F30
									
27.1x7.7x9.8	24.9x7.7x10.0	24.9x7.7x10.0	27.1x7.7x15.3	24.9x7.7x15.5	24.9x7.7x15.3	24.9x7.7x15.5	15.7x7.7x8.5	24.7x7.2x9.5	24.9x7.7x11.0
PS-22F31 PS-22F34	PS-22F33 PS-22F35	PS-22F36	PS-22F37	PS-22F38	PS-22F39	PS-22F40	PS-22F41	PS-22F43	PS-22F45
									
24.9x25.6x10.0	27.1x7.7x15.3	15.7x18.0x8.5	24.9x25.6x10.0	24.9x7.7x10.4	24.9x23.8x9.8	24.9x23.8x9.8	24.9x7.7x15.5	24.9x7.7x15.5	27.1x7.7x15.3
PS-22F46	PS-22F47	PS-22F48	PS-22F49	PS-22F50	PS-22F52	PS-22F54	PS-22F56	PS-22F58	PS-22F59

PUSH SWITCHES

									
24.9x7.7x10.0	24.9x7.7x10.0	24.9x23.8x9.8	24.9x7.7x15.5	24.9x7.7x25.6	24.7x7.7x15.3	24.9x23.8x9.8	24.7x7.7x15.3	15.7x7.7x8.5	15.7x7.7x8.5
PS-22F60	PS-22F61	PS-22F62	PS-22F65	PS-22F66	PS-22F68	PS-22F72	PS-22F78	PS-22F91	PS-22F92
									
15.7x7.7x8.5	15.7x18.0x8.5	15.7x18.0x8.5	21.2x7.7x10.2	22.4x7.7x10.2	171x24.0x9.2	17.0x8.0x8.0	34.0x7.8x11.3	20.0x6.0x5.5	20.0x6.5x6.2
PS-22F93	PS-22F94	PS-22F98	PS-22F201	PS-22F202	PS-22F301	PS-22H01	PS-22I48	PS-42D01	PS-42D02
									
19.2x7.0x10.5	30.5x7.0x10.5	20.0x6.0x5.5	20.2x6.5x6.2	19.0x7.0x10.5	28.5x7.0x10.5	36.9x9.4x11.6	36.9x9.4x11.1	24.3x9.4x11.1	25.3x9.4x11.1
PS-42D04	PS-42D06	PS-42D11	PS-42D22	PS-42D24	PS-42D25	PS-42F01	PS-42F02	PS-42F03	PS-42F05
									
27.3x9.4x11.6	26.9x9.4x11.1	30.8x9.4x11.1	27.8x9.4x11.1	24.3x9.4x11.1	26.9x9.4x11.6	24.3x9.4x11.6	26.3x9.4x11.1	27.3x9.4x11.1	27.3x9.4x11.6
PS-42F06	PS-42F07	PS-42F08	PS-42F09	PS-42F10	PS-42F11	PS-42F13	PS-42F15	PS-42F16	PS-42F17
									
26.9x9.4x12.5	24.3x9.4x12.5	31.3x9.4x12.5	26.3x9.4x12.5	26.9x9.4x11.6	24.9x7.5x9.8	33.12x9.4x11.1	50.3x5.0x12.7	25.7x6.2x5.0	50.3x5.0x10.0
PS-42F21	PS-42F23	PS-42F25	PS-42F26	PS-42F31	PS-42F42	PS-42F45	PS-62D01	PS-62D02	PS-62D03
									
50.0x5.0x12.0	26.2x6.5x6.2	50.0x5.0x12.0	50.3x5.0x10.0	50.3x5.0x10.0	50.3x5.0x10.0	26.0x6.2x5.0	38.0x5.2x10.0	26.2x6.5x6.2	25.7x6.2x5.0
PS-62D05	PS-62D08	PS-62D09	PS-62D11	PS-62D12	PS-62D13	PS-62D14	PS-62D16	PS-62D18	PS-62D20
									
61.2x5.8x12.0	61.2x5.8x12.0	32.2x6.5x6.0	32.2x6.5x6.0	32.2x6.5x6.0	32.2x6.5x9.1	32.0x9.5x6.2	68.0x5.3x10.0	68.0x5.2x10.0	38.0x6.5x6.2
PS-62E01	PS-62E03	PS-82D02	PS-82D03	PS-82D04	PS-82D06	PS-82D16	PS-92D01	PS-92D04	PS-102D02
									
36.0x6.5x6.2	38.0x6.5x6.2	13.0x7.5x6.5	13.0x7.5x6.5	13.0x7.5x6.5					
PS-102D03	PS-102D05	PS-11B-SK13D01	PS-11B-SK13D02	PS-11B-SK13D03					

All specifications subject to change without notice. Drawings are available on request. General tolerance ± 0.2 mm. Units: mm. „+“ - more types are available.

PBS PUSH SWITCHES

24.8x7.4x8.9	26.0x7.4x7.5	26.0x7.4x7.5	30.8x8.2x12.8	42.8x9.8x14.8	33.5x7.4x7.5	33.5x7.4x7.5	38.3x8.2x12.8	54.0x9.8x14.8	40.0x7.4x7.4
PBS-22C02	PBS-22D01	PBS-22D02	PBS-22E01	PBS-22H01	PBS-42D01	PBS-42D02	PBS-42E01	PBS-42H01	PBS-62E06

66.0x9.8x14.8									
PBS-62H01									

BOTTOM SWITCHES

20.2x11.6x10.5	20.2x11.6x10.5	20.2x11.6x10.5	13.0x11.6x8.0	18.5x10.5x9.0	13.0x11.6x8.0	20.2x11.6x10.5	13.0x11.6x8.0	18.5x10.5x9.0	23.0x11.6x10.5
BK-22F01	BK-22H01	BK-22H02	BK-22H03	BK-22H05	BK-22H13	BK-23D01	BK-23D03	BK-23D04	BK-24D01

24.0x11.8x10.5	24.0x11.8x10.5	34.0x11.8x10.5	34.0x11.8x10.5						
BK-42H01	BK-43D01	BK-62H01	BK-63D01						

TOGGLE SWITCHES

23.0x10.8x12.0	23.0x10.8x12.0	23.0x10.8x12.0	23.0x10.8x12.0	23.0x10.8x12.0	23.0x10.8x12.0	23.0x10.8x12.0	23.0x10.8x12.0	23.0x10.8x12.0	23.0x10.8x12.0
TS-22E01	TS-22E04	TS-22E05	TS-22J03	TS-22J05	TS-23E01	TS-23E02	TS-23E06	TS-42E05	TS-42E06

39.6x10.8x30.2	39.6x10.8x35.2	39.6x10.8x30.2	39.6x10.8x35.2	52.0x10.8x30.2	52.0x10.8x35.2	52.0x10.8x30.2	52.0x10.8x35.2	75.0x10.8x30.2	75.0x10.8x35.2
TS-42J01	TS-42J03	TS-43E01	TS-43E03	TS-62J01	TS-62J03	TS-63E01	TS-63E03	TS-84E01	TS-84E03

40.5x10.9x15.5	40.5x10.9x15.5	40.5x10.9x15.5	40.5x10.9x15.5	53.0x10.9x15.5	53.0x10.9x15.5	53.0x10.9x15.5	53.0x10.9x15.5	78.2x10.9x15.5	78.2x10.9x15.5
NS-42E02	NS-42J01	NS-42J03	NS-43E01	NS-62J01	NS-62J03	NS-63E01	NS-63E03	NS-84E01	NS-84E02

26.0x9.4x16.9	40.5x10.9x15.5	54.5x10.9x15.5	40.5x10.9x15.5	53.0x10.9x15.5	53.0x10.9x15.5	54.0x7.6x13.5	65.5x10.9x15.5		
LS-24D01	LS-42J01	LS-43E01	LS-43E11	LS-62J01	LS-63E01	LS-83D01	LS-83E01		

All specifications subject to change without notice. Drawings are available on request. General tolerance ± 0.2 mm. Units: mm. „+“ - more types are available.

DC POWER JACKS / DIN JACKS

14.5x9.0x11.0	21.0xØ8.1	21.0xØ10.8	21.0xØ8.1	25.4xØ13.8	13.1x9.0x20.2	11.8x9.0x20.2	14.5x9.0x11.0	15.5x12.5x9.0	14.5x9.0x11.0
DS-012	DS-025	DS-026	DS-046	DS-048	DS-204	DS-205	DS-208	DS-209	DS-210
14.5x9.0x11.0	9.0x6.2x5.0	11.8x9.0x20.2	15.5x12.5x9.0	15.5x12.5x9.0	22.6x9.0x11.0	11.3x5.0x7.4	13.4x9.0x11.0	11.8x9.0x20.5	11.8x9.0x20.5
DS-211	DS-213	DS-215	DS-218	DS-219	DS-220	DS-222	DS-223	DS-225	DS-226
13.7x13.0x15.5	11.8x9.0x15.6	11.7x9.0x20.5	14.5x9.0x11.0	14.5x9.0x11.0	14.5x9.0x11.0	14.5x9.0x11.0	18.5x13.0x15.5	11.2x5.0x7.0	12.2x10.5x8.2
DS-229	DS-235	DS-236	DS-241	DS-242	DS-243	DS-248	DS-259A -DS-259G	DS-303	DS-306
12.2x8.0x9.5	15.5x12.5x9.0	11.2x5.0x7.4	11.2x5.0x7.4	11.5x5.0x7.4	10.7x14.2x10.1	11.0x6.0x5.2	16.0x11.0x9.5	13.2x16.0x8.0	9.3x8.0x5.3
DS-308	DS-309	DS-313	DS-314	DS-383	DS-404	DS-413	DS-414	DS-415	DS-422
11.0x6.0x5.2	10.8x4.35x4.7	12.5x14.0x13.0	13.0x14.0x13.2	13.0x15.0x14.0					
DS-423	DS-613	DIN-001	DIN-002	DIN-003					

AC SOCKETS



24.7x32.4x22.0	24.7x32.4x22.0	16.5x34.2x14.5	24.7x32.4x22.0	25.4x33.0x24.0	23.6x33.2x22.2	22.0x32.4x22.0	16.5x34.2x14.5	16.5x34.2x14.5	16.5x22.0x14.5
AS-203B	AS-203S	AS-204	AS-206S	AS-208	AS-209	AS-211	AS-214	AS-215	AS-224
16.5x34.2x14.5	16.5x34.2x14.5	16.6x34.2x14.5	20.3x34.2x14.5						
AS-264	AS-338	AS-339	AS-341						

AUDIO PLUGS



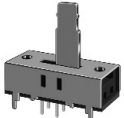
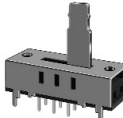
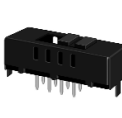
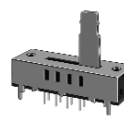
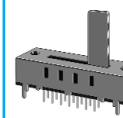
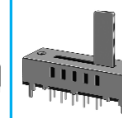
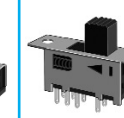
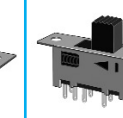
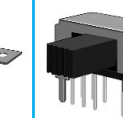
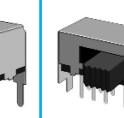
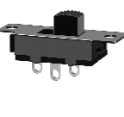
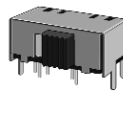
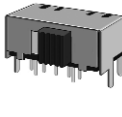
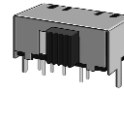

47.2xØ6.3	49.2xØ5.9	50.2xØ6.6	84.5xØ8.3	85.4xØ8.3	41.0xØ5.7	35.4xØ5.5	35.2xØ5.5	34.7xØ9.1
MP-252	MP-352	MP-353	MP-642	MP-643	DP-5520-S	DP-5520-L	DP-5525-M	RP-321

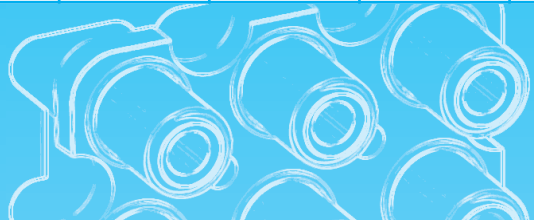
All specifications subject to change without notice. Drawings are available on request. General tolerance ±0.2 mm. Units: mm. „+“ - more types are available.

SPECIAL FUNCTION SWITCHES

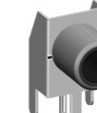
									
24.0x9.5x10.2	28.0x9.5x10.2	25.0x8.0x9.0	32.0x9.5x10.2	44.0x9.4x10.0	36.0x9.5x10.2	24.0x6.5x8.8	24.0x6.5x8.8	14.0x6.5x8.5	20.0x9.4x12.0
EX-22H01	EX-33H01	EX-44F01	EX-44H01	EX-44P01	EX-55H01	PSS-23E07	PSS-23E08	PSK-23D09	PSK-23E01
									
35.0x13.4x11.0	13.0x7.5x6.5	13.0x7.5x6.5	13.0x7.5x6.5	21.6x11.0x7.0					
PS-12103	PS-11B-SK13D01	PS-11B-SK13D02	PS-11B-SK13D03	DL-001					

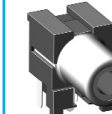

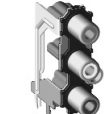
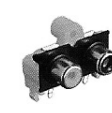
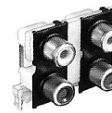























RCA JACKS

									
13.0x14.2x13.0	19.2x21.3x19.4	15.3x10.6x12.0	15.2x11.0x12.3	15.3x10.6x12.0	12.0x10.0x10.5	19.2x10.0x13.0	27.0x13.5x11.0	23.5x14.2x14.4	11.0x12.8x6.6
CS-104	CS-105	RC-101	RC-103	RC-104	RC-106	RC-125	RC-127	RC-129	RC-139
									
16.0x10.5x10.5	21.5x10.0x12.5	20.5x9.7x10.8	19.5x10.0x13.0	19.5x10.0x13.0	25.3x28.0x21.4	22.3x52.8x20.8	19.5x40.0x13.5	25.0x10.5x43.6	22.0x13.0x41.0
RC-140	RC-141	RC-142	RC-145	RC-155	RC-216BB	RC-248	RC-325	RC-331	RC-333
									
21.0x40.0x17.8	20.0x33.8x27.2	21.0x55.0x12.5	19.4x40.8x26.9	21.5x54.7x27.0	22.7x13.0x20.2	19.3x13.5x28.5	16.3x27.2x20.5	18.8x41.0x20.5	20.1x34.0x27.4
RC-339	RC-429	RC-434	RC-622	RC-833	RC-2000	RC-2001	RC-2002	RC-2003	RC-2004







AC ROCKER SWITCHES

									
21.5x12.5x25.8	32.0x12.5x25.8	34.6x12.5x25.8	35.5x12.6x22.0	28.0x13.8x15.0	34.6x12.5x25.8	44.5x11.8x23.8	25.0x5.4x12.9	32.0x16.8x27.4	32.5x16.8x27.4
RS-1122	RS-1132	RS-1135	RS-1136	RS-1138	RS-1139	RS-1145	RS-1220	RS-115SBK	RS-115TBK
									
∅ 20.8x16.7	∅ 20.8x16.7	21.0x15.0x16.6	21.0x15.0x16.6	21.0x15.0x16.6	21.0x15.0x16.6	21.0x15.0x16.6	21.0x15.0x16.6		
RS-12R0	RS-12L0	RS-13A0	RS-13B0	RS-13C0	RS-13D0	RS-13E0	RS-13F0		

USB CONNECTORS

				
13.65x14.5x7.12	13.0x14.5x7.12	13.0x14.5x7.12	13.0x14.5x7.12	14.0x14.5x7.12
USB-A1D162F-1L9N-W	USB-A1D42F-0B4N	USB-A1D42F-0N4N	USB-A1D42F-0W4N	USB-A1M07F-0B4N
				
14.0x14.5x7.12	14.0x14.5x7.12	18.8x12.0x4.5	20.0x12.0x4.5	18.3x15.2x5.12
USB-A1M07F-0N4N	USB-A1M07F-0W4N	USB-A1M67M-0N4N-W	USB-A1S10M-0N4N	USB-A1S81F-4L9N-W
				
17.0x14.5x15.5	17.0x14.5x15.5	16.5x12.04x11.5	16.5x12.04x11.5	16.5x12.04x11.5
USB-A2D16F-0B8N	USB-A2D16F-0W8N	USB-B1D08F-0B4N	USB-B1D08F-0N4N	USB-B1D08F-0W4N
				
16.1x12.2x11.2	16.1x12.2x11.2	16.1x12.2x11.2	9.2x6.9x3.1	16.15x12.04x11.2
USB-B1D124F-0B4N	USB-B1D124F-0N4N	USB-B1D124F-0W4N	MIN-B1M16F-0B5N	USB-B1S01F-0B4N
				
16.15x12.04x11.2	16.15x12.04x11.2	13.5x7.05x4.6	4.3x7.91x2.35	36.5x10.75x9.25
USB-B1S01F-0N4N	USB-B1S01F-0W4N	MIR-B1S03M-0B5N	MIR-CIM07F-0B5N	USB-A1S169M-4L9N-W
				
36.3x8.5x10.44	11.8x7.6x1.95	11.8x7.62x1.95	17.0x7.6x1.3	71x8.0x4.0
USB-B1S17M-4L9N-W	SCR-001	SCR-002	SCR-003	BN-3250

HDMI CONNECTORS

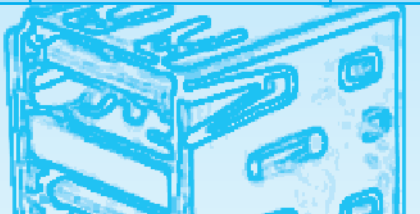
				
11.55x15.0x15.98	11.55x15.0x6.18	11.55x15.0x6.18	17.3x13.9x4.45	20.7x15.0x4.45
HDI-A1M07F-0B19N	HDI-A1M13F-0B19N	HDI-A1M13F-1B9N	HDI-A1S04M-0B19N	HDI-A1S08M-3B19N
				
17.5x13.7x8.5				
HDI-A1S43F-0B6N				

TCM SERIES

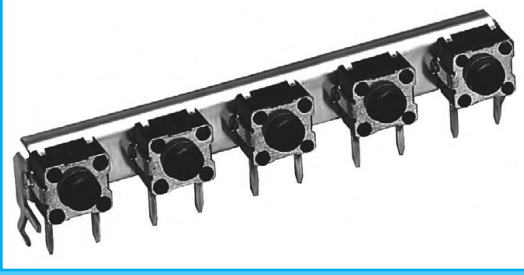

TCM = 1 5 A T

OPERATING FORCE

O/ FORCE	100gf	130gf	160gf	190gf	250gf
CODE	T	V	X	Y	Z

STEM LENGTH (UNIT: mm)

L	3.15	3.85	5.85	6.15	6.85	8.35	11.35	12.35
CODE	A	B	C	D	E	F	G	H

NUMBER OF KEYS

No. of Keys	3	4	5	6	7	8	9
CODE	3	4	5	6	7	8	9

KEY PITCH (UNIT: mm)

KEY PITCH	10	15
CODE	1	2

TCM SERIES

TCM SERIES 5 Keys Code 1

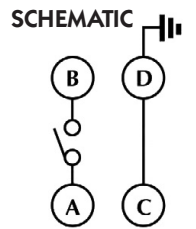
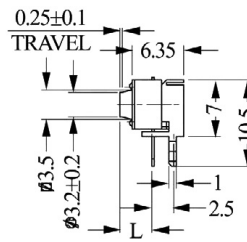
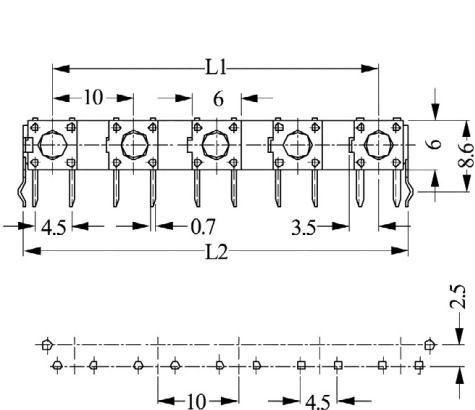

No. of Keys	3	4	5	6	7	8	9
L1	20		40		60		80
L2	27		47		67		87

TCM SERIES 5 Keys Code 2

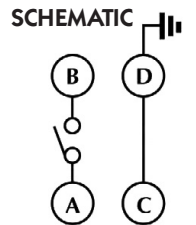
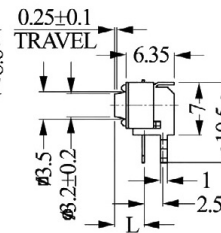
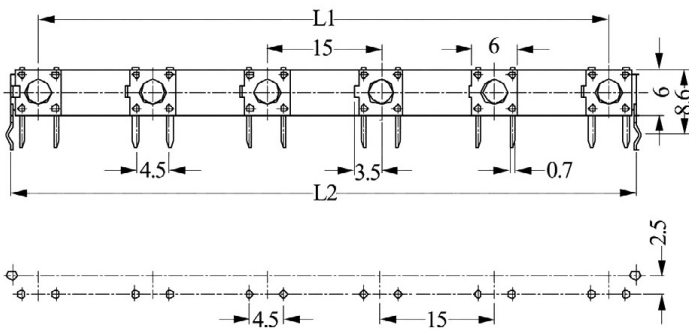

No. of Keys	3	4	5	6	7	8	9
L1		45	60				
L2			67				

TCM SERIES

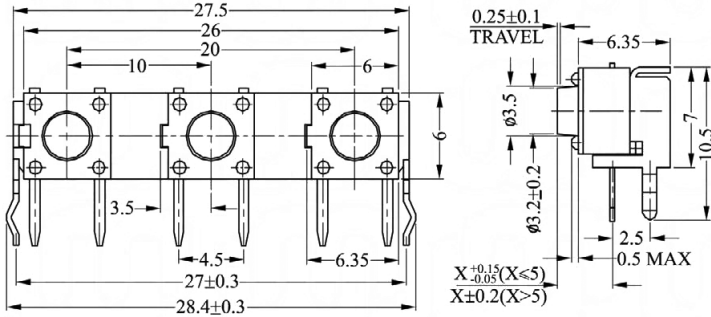

TCM-13AT ~ 13HZ

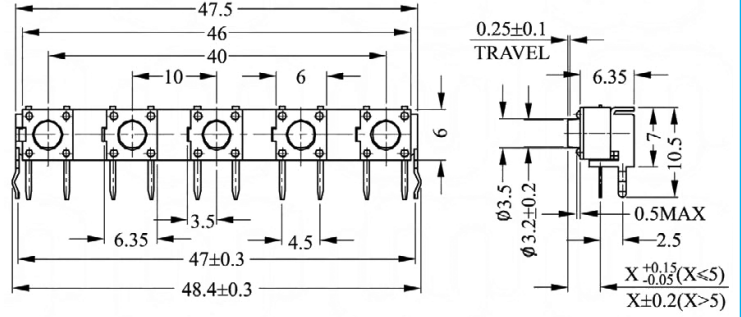

TCM-15AT ~ 15HZ

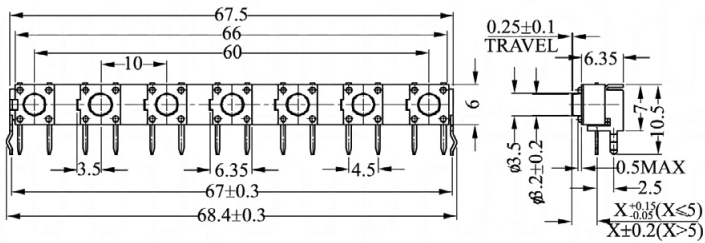

TCM-17AT ~ 17HZ

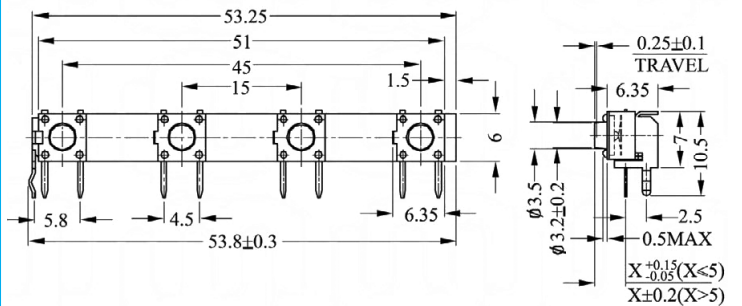

TCM-24CAT ~ 24CHZ

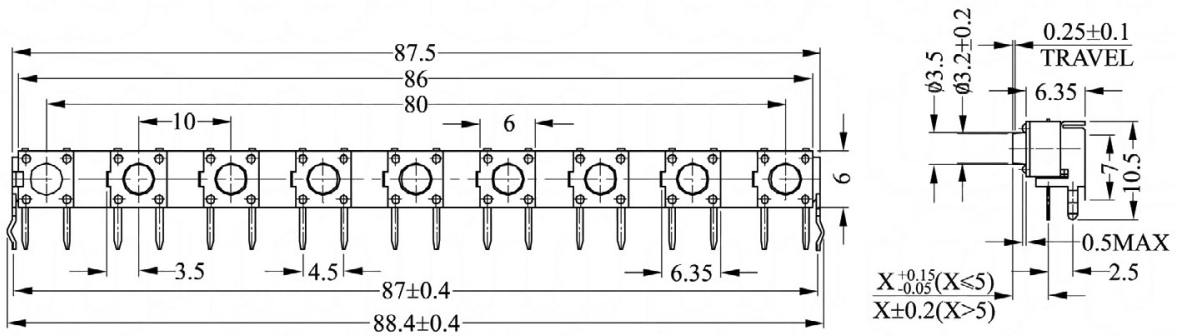

TCM-19AT ~ 19HZ

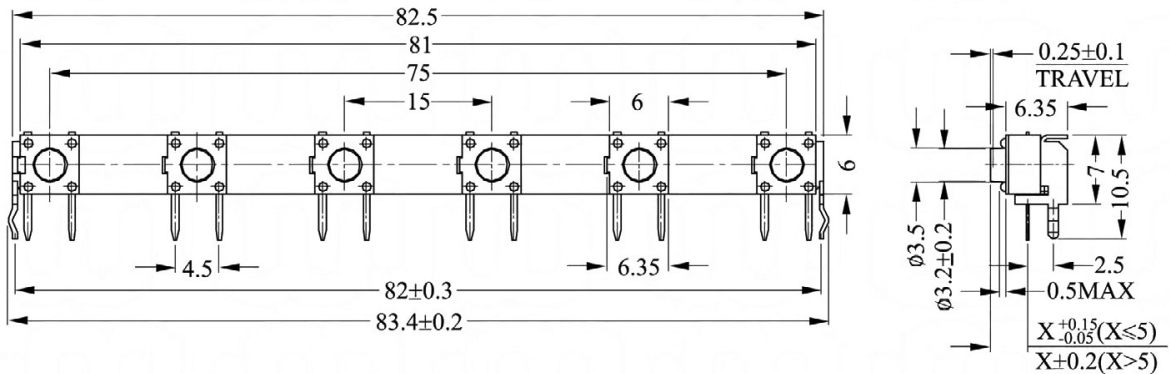

TCM-26AT ~ 26HZ

KNOB TABLE

AM Metal Knob	AT ADD Aluminium Sleeve	AY ADD Aluminium Sleeve	BM Metal Knob	BU Metal Knob	BV Metal Knob	BI Metal Knob	FM
GA	GC	GD	GE	GS	GX	HG	LM Metal Knob
LS	LU Metal Knob	MX Metal Knob	NT	NY	PG	PM Metal Knob	RA
RB	RD	RG	SM Metal Knob	SU Metal Knob	TA	TB	TC
TD	TE	TF	TG	TH	TK Metal Knob	TP	TR
TS	TM Metal Knob	TO	UA Metal Knob	UB Metal Knob	UC	UD	UM Metal Knob
VA	VB	VC	VD	WA	WB	WC	WG

ACCESSORIES

<p>AZ-001 Hexagon Nut</p>	<p>AZ-002 Hexagon Nut</p>	<p>AZ-003 Hexagon Nut</p>	<p>AZ-004 Round Nut with Slot</p>
<p>AZ-005 Round Nut with Slot</p>	<p>AZ-006 Round Washer</p>	<p>AZ-007 Spring Washer</p>	<p>AZ-008 Spring Washer</p>
<p>AZ-009 Keycap</p>	<p>AZ-010 Keycap</p>	<p>AZ-011 Keycap</p>	<p>AZ-012 Keycap</p>
<p>AZ-013 Keycap</p>			



digital electronic
siegfried lehrer gmbh

Rudolf-Wanzl-Str. 3+5
D-89340 Leipheim / Germany
www.digital-lehrer.de
digital@digital-lehrer.de
Tel. +49 (0) 82 21 70 8-0
Fax +49 (0) 82 21 70 8-80

seit
since **1981**

switches ...
and more

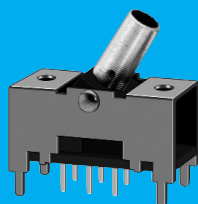
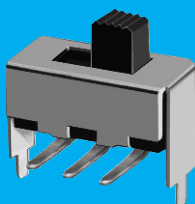
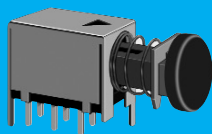
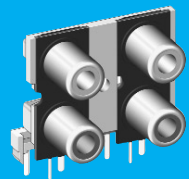
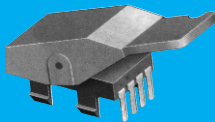
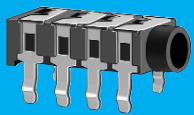

RoHS compliant 2002/95/EC

