

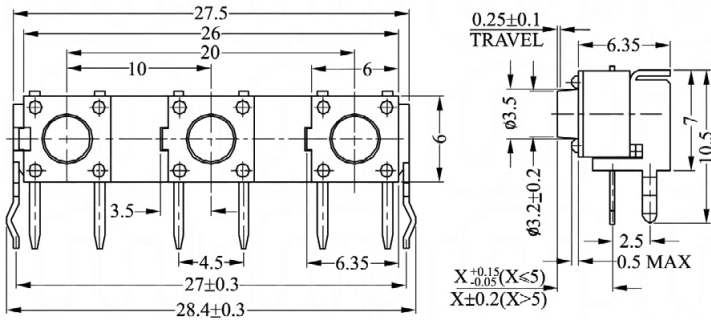

# TCM SERIES

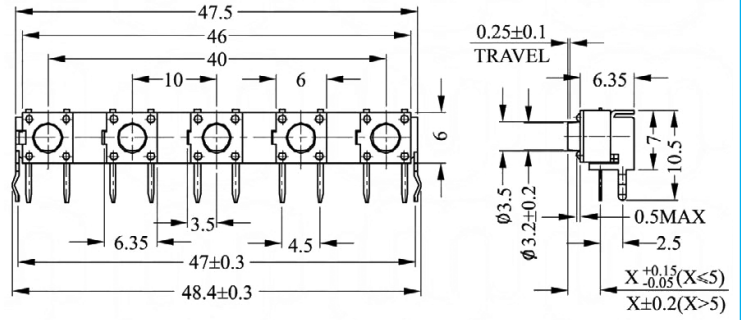

TCM-13AT ~ 13HZ



TCM-15AT ~ 15HZ

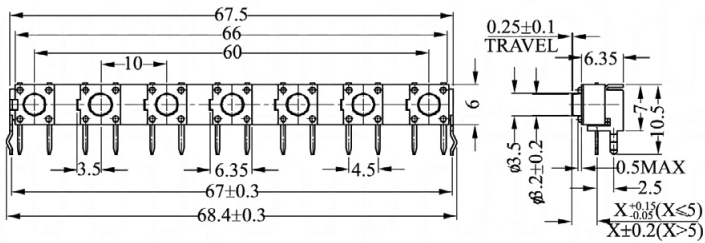

TCM-17AT ~ 17HZ

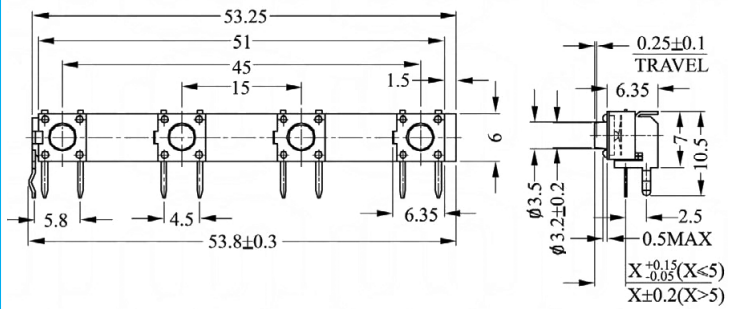

TCM-24CAT ~ 24CHZ

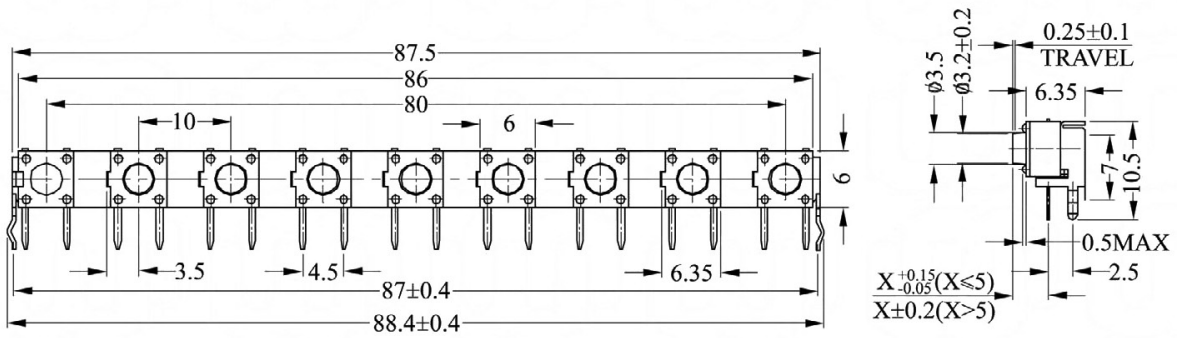

TCM-19AT ~ 19HZ

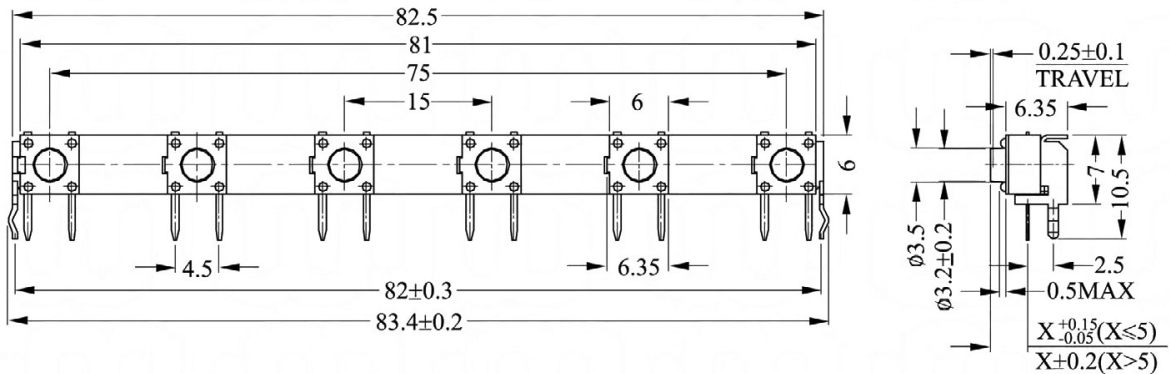

TCM-26AT ~ 26HZ

All specifications subject to change without notice. Drawings are available on request. General tolerance  $\pm 0.2$  mm. Units: mm. „+“ - more types are available.